

# INDEX

<b>Topics</b>	<b>Page</b>
INTRODUCTION .....	3
1. APPLICATION OF VAASTUSHASTRA .....	7
2. BASIC PRINCIPLES OF VAASTU .....	9
3. NATURE OF THE GLOBE AS PER VAASTU .....	15
4. THE BIRTH OF VAASTU PURUSHA .....	20
5. THE FIVE MAIN ELEMENTS .....	24
6. SCIENTIFIC VAASTU .....	28
7. WHETHER THE SCIENCE OF VAASTU IS BELIEV- ABLE? .....	35
8. DIRECTION ACCORDING TO ZODIAC SIGN .....	39
9. GEOPATHIC STRESS .....	49
10. ENERGY LEVEL INSIDE THE PLOT .....	58
11. DIRECTIONS HOW TO CHECK .....	63
12. DIRECTIONS IN THE PLOT AND BUILDING .....	67
13. SELECTION OF LAND/PLOT .....	72
14. EFFECT OF THE CORNERS .....	103
15. SLOPE OF LAND .....	106
16. PROPER SOIL SELECTION .....	112
17. COMPOUND WALL OF THE BUILDING .....	113
18. LOCATION OF THE WELL/ BORING .....	115
19. OVER - HEAD TANK .....	119
20. OBSTACLES IN FRONT OF ENTERANCE .....	120
21. VEEDI SHOOLAS .....	124
22. VARIOUS PARTS OF A HOUSE .....	132
23. DIAGONAL PLOTS .....	139
24. INTERNAL PLANNING OF A HOUSE .....	151
25. I, L, U, E SHAPE BUILDING .....	178
26. FACTORIES .....	182
27. BANKS .....	184
28. EDUCATIONAL INSTITUTES .....	186
29. HOSPITALS .....	188

**Advance Vaastu**

30. SHOPS .....	190
31. PURCHASE OF THE ADJACENT PLOTS .....	192
32. PORCH & PARKING .....	193
33. EVALUATION EXERCISES FOR A HOUSE AND FLAT .....	194
34. SOME IMPORTANT SUGGESTIONS .....	205
35. AUSPICIOUS COLOURS OF THE BUILDING .....	209
36. QUESTIONS & ANSWERS .....	210
37. PYRA VAASTU AND PYRAMIDS .....	237
38. INTRODUCTION ABOUT FENG - SHUI .....	246
39. OVERCOMING VAASTU DEFECTS BY USING FENG - SHUI .....	248
40. 21 FENG-SHUI TIPS FOR EXCELLENT RESULTS .	256

# **INTRODUCTION**

---

---

**Vaastu -Shastra** is a Vast and ancient science of living. The word Vaastu is derived from the root ‘**Vas**’ which means ‘**to reside**’.

It is not an equivalent of the word architecture. Vaastu is architecture and much more. While architecture is the science, art or profession of designing and constructing buildings etc., the definition of Vaastu extend into the realm of occultism. Vaastu Shastra, the edifice science of Bhawan Sthapatya Kala, being the applied aspects of ATHARVAVEDA, is an ancient science and one of the eminent features of our heritage.

Vaastu means dwelling of Humans and Gods in the original Sanskrit literature.

Many factors govern the life of a human being ; his fate, Karma and surroundings. **BUT VAASTU CAN MAKE SWEET THINGS SWEETER AND BITTER LESS BITTER.**

Like many of our traditions, Vaastu too got neglected over the centuries for want of patronage; hence the present society could not very much appreciate and utilise this science in their construction of house, shops, office or industrial complexes. **If construction is not according to the principles of “VAASTU” then thinking and action of the people dwelling or working in these places is not harmonious and evolutionary; leading to disorder & illness.**

This is one of the main reason of discontent and sufferings of the society at present. On the contrary, if the laws **of nature which are elaborated and incorporated in the**

**science of Vaastu** are followed, then all the Divine powers support the thinking and action of the people associated with such concerns.

Building a house in ancient India was not only a house-craft but also a sacred ceremony and the house was considered a living organism. The spirit of the house was called the Vaastu Purusha and different cardinal directions and sectors were assigned to different Gods like Brahma, Ishwara, Agni, Varun, Wind, Yam and Demon, since the waves flowing in a particular direction have a specific influence. Eeshan or north east is presided over by God and is therefore suitable for a prayer room. The southeast belongs to Agni. The central space is Brahma's and should be left open to the heavens. The head and limbs of the Vaastu Purusha are to be left alone too.

If the various activities in a house, shop, office or industry are directionally channelised as per principles of Vaastu, we begin to draw power from nature in a natural way. ONCE THIS IMMENSE FORCE OF ALMIGHTY BEGINS TO SUPPORT US, ALL OUR OBJECTIVES ARE FULFILLED IN EASY, SPONTANEOUS AND EFFORTLESS MANNER.

The Shastra is being gradually applied not only in Houses but also in Commercial buildings and industries, where the clients stakes are high. For example, Vaastu assigns the kitchens, chimneys, Furnace, boiler etc. to a certain corner on the basis of wind directions to prevent the smoke and cooking fumes from flowing into the living/working area and affecting the health of the residents/ workers. **Thus there is a great need for the architects and Vaastu Engineers to coordinate; since an architect can build a posh house but can't assure happy life to the people living in that house, whereas Vaastu -science assures**

**peace, prosperity and progress to the owner as also the inmates.** This happy admixture of ancient heritage and modern science can go a long way in reviving this edifice science.

Gradually this science is spreading fast from Kerala, Tamilnadu, Andhra Pradesh, Maharashtra, Madhya Pradesh, Rajasthan to Delhi. In nutshell “ Vaastu” lays down principles for construction of the houses, commercial buildings and industries etc. Which harmonies with the neighborhood, nature and the entire universe.

Many rules are common sense as they relate to ventilation and sunlight But some like the subtle energy in natural and built environments that affect humans have also been verified and appreciated by those who did not believe in them initially.

Sun is the major cosmic entity which radiates light & heat in entire universe. It is called soul of the universe “SURYA ATMA JAGATAS TASTHU KHASHCHA”. The principles of Vaastu allows human beings & society with inexhaustible source of energy and thus make them to live in fully satisfied manner.

We live on earth, which nourishes all beings like a mother and is treasure of all comforts & pleasure. The all embarrassing motherly role of earth is best tapped by use of principles of “Vaastu”.

Along with construction, the internal decoration in the house, shop or factory is equally important. IF SETTING OF THINGS ARE ACCORDING TO PRINCIPLES OF VAASTU, THE THOUGHTS, SPEECH & ACTION ARE SUPPORTED BY NATURE AND LEAD TO HEALTH WEALTH AND HAPPI-

NESS.

Vaastu's current revival may be confined to human dwellings, but the scope of the shastra, also known as Sthapatya-Veda extends to temple-design, iconometry, town planning & civil engineering as well.

Most well known temples in South India like Lord Venkateswara Temple at Tirupathi, Meenakshi Temple at Madurai etc. are Vaastu -perfect. It terms of entire city Jaipur was founded in 1727 by Maharaja Sawai Jai Singh II in accordance with Vaastu Shastra.

In addition to Karmas in this life, two things fate and Vaastu affect the life of a person; each responsible for 50% happiness in life. If Vaastu is poor the result as compared to efforts will be half even if the stars are exalted & the fate is very strong. As against this if "Vaastu" is right and the planetary position is unfavorable than also the ill effects will not be so bad, as to that when both are poor. This means that if a house or industry is constructed according to "Vaastu"  
**MAN'S DESTINY MAY BE CHANGED FOR THE BETTER. ●**

\*\*\*\*\*

# 1. APPLICATION OF VAASTUSHASTRA

---

---

In the world everything, substance, man and other animals are made from the *Panchmahabhoot* that is the five basic elements. The earth, the water, the fire, the wind and the sky. The five elements have close relationship with man and his environment. Nature has given them their proper place according to merit.

If we give proper place to these elements at proper places in our building we become one with Nature. Actually nature is the God. One can experience the eternal truth of nature on every step. The whole nature is overpowered with magnetic environment.

The modern man has waged a war with nature in many fields. We can see nature with our own eyes and we can experience the *Panchmahabootas*. Going against them would lead us to sure destruction. Taking the surroundings and the proper places for these elements into consideration, the sages and seers introduced *Vaastushastra*. For showing themselves rational, some people think *Vaastushastra* as superstitious. This is really a great misfortune for them.

In the old times maximum use of wood was made in the construction. Wood is a bad conductor of electricity and as such does not interfere with the power in environment. Today wood being very costly, minimum use of wood is made in the construction. On the other hand steel, iron, aluminium etc. metals are used on a large scale. With their divine vision the sages and seers created *Vaastushastra* so that a man should live a happy and prosperous life with his family.

Many a times a man purchases a place (plot) or house because it is cheap. He does not pay any attention to

the usefulness or harmfulness of the same. If he purchases a place, plot or building using the principles of *Vaastushastra*, his economic front definitely improves and gets peace and prosperity. However, if the selection goes wrong it leads to financial losses, untimely deaths of important people, gap in the education of children etc. He then turns to God. After taking all possible measures if the position remains bad he blames his fate.

There is no denying the fact that mental peace is definitely derived if we build our house using *Vaastushastra*. Many a times we are living in a house which is built as per the norms of *Vaastushastra*. Probably we have not even heard of this science. Many a times we change our old residence and move to a new one. We do not get the same peace of mind, happiness and prosperity. On the other hand, there are clashes and financial losses. In such cases we should show the building to an expert on *Vaastushastra* and make the necessary changes. While giving guidance to many people at Bombay, Pune, Aurangabad, Nasik, Nagpur, Delhi, Calcutta, United States, Malaysia Singapore & Nairobi, we observed that after making necessary changes it took at least 21 days before the building started giving fruits of the labour. At some places this time period extended to 90 days.

Without *Karma* (Action) there are no fruits. But if we are not getting the returns after good *Karma* then, by following *Vaastushastra* we can remove the defects in the structure and enjoy the fruits. However, if after removing the defects in the house, we don't do any thing, progress is not possible. *Karma* needs the help and support of the basic elements, nature and environment. To make changes in our building structure as per *Vaastushastra* is also a sort of work i.e. *Karma*.

\*\*\*\*\*

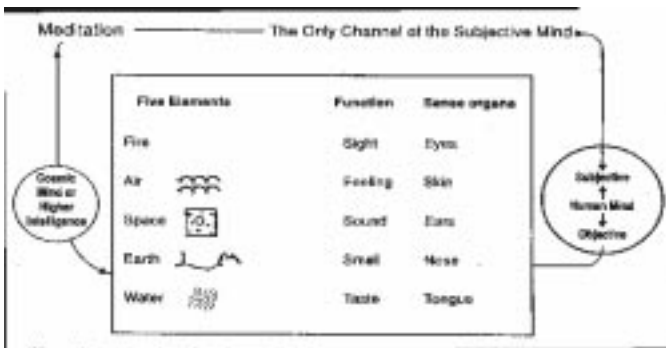


## 2. Basic Principles of Vaastu

Since the whole universe is a composition of five basic elements: Fire, Air, Space, Earth and Water. Through these, our body receives Internal Energies in the form of Proteins, Carbohydrates, Fats etc. and External Energies in the form of Heat, Light, Sound, Wind and so on .

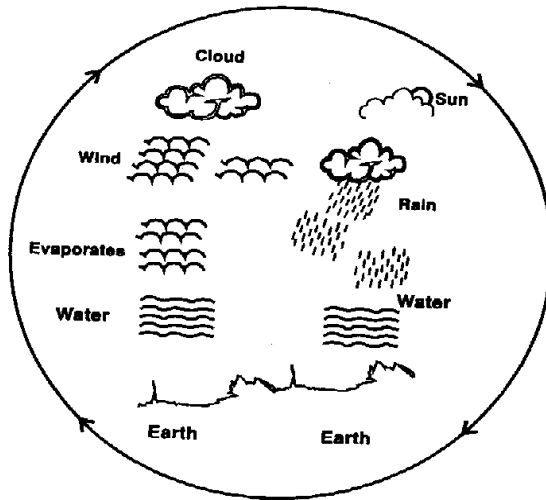
The basic principles of Vaastu enables us to achieve balance among these ; giving more flexibility of body & mind for a better life .

When the harmony between these elements gets disturbed our energies get dissipated in different directions leading to stress, tension and ill health and our peace of mind is destroyed. We then have to redirect our Energies subjectively as well objectively , so as to achieve an equilibrium between Internal / External Energies, to attain a healthy body and a happy mind leading to health, wealth, happiness, prosperity and success .



The diagrams showing interaction of human mind with the Cosmic Mind.

The natural cycle of the elements is given here under.



The water from the Earth evaporates into the atmosphere (Space) due to the heat in our Solar System (Sun). These droplets of water accumulate to form clouds. The Air which moves the clouds makes them release the excess water which comes back to the Earth in the form of Rain . Thus the Cycle , as well as the equilibrium of the elements , is maintained on our planet.

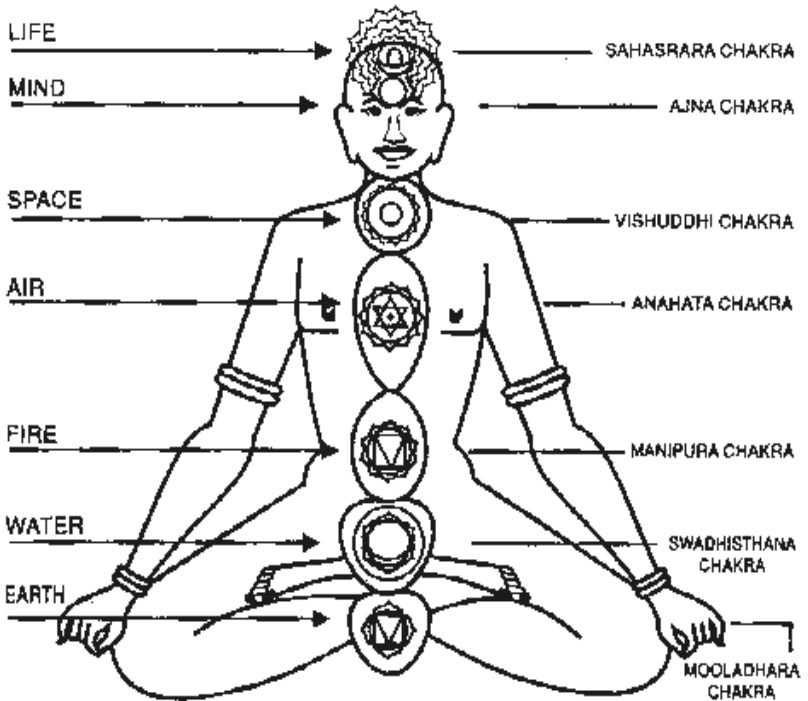
To experience the above Cycle you need a mind and to have a mind you need life. Therefore the 5 elements + Mind + Life become the cause of our existence.

When the Life force comes out of this cycle it merges with the Cosmic force. You are then no longer a part of the Cycle you become the Cause.

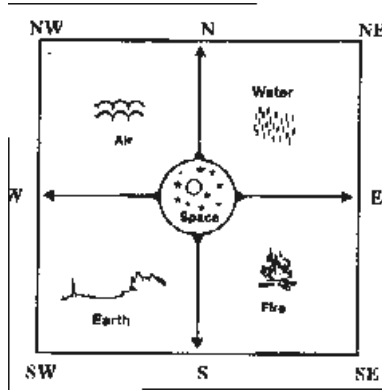
This merger of the Life force with the Cosmic force is affected by detachment / meditation ,in simpler words, you become a Tatva-Ateetha. That which is above the elements ( tatvas ) .

The above Energy Cycle is radiation energies corresponding to an element such as :

FORM OF ENERGY	ELEMENT
SOLAR	FIRE
WIND	AIR
RAIN	WATER
GRAVITATIONAL / MAGNETIC	EARTH
SOUND	SPACE



This is this placement of universal elements in relation to the four principal directions :



For better results, any activity in your residence or office should be supplemented by the cosmic position of the elements.

**The North-East (NE) is assigned to Water :** Have a bore well, underground water tank in that position.

**The South-East (SE) is assigned to Fire :** Have your kitchen, pantry, furnace, boiler there.

**The North-West (NW) is assigned to Air :** There have a guest-room bed room for unmarried girls or a store for finished goods .

**The South-West (SW) is assigned to Earth :** It is the most stable of all elements. Keep it heavy and this is the best place for master Bed Room.

**The Centre is assigned to Space :** Have the least possible activity in this area.

How does an imbalance in these elements affect us ? An imbalance in these elements in the natural cycle causes Floods , Typhoons, Volcanoes, Earthquakes and so on .

Similarly, an imbalance of these elements in our diet can easily be felt physically . The food that we eat gives us energy. If our diet is balanced, our body gets the necessary energy and we feel good. When there is an excess of some element in our diet, say, fire, that is , an excess of spices or chillies, there will be acidity. The( physical )discomfort in our stomach will guide us to have antiacid tablets as well as a change in diet.

Likewise, an imbalance of these elements outside our body in our surroundings creates a discomfort which we do not feel physically but experience mentally as energy centres (Chakras) of the body get disturbed .

Whenever we are trying to balance/attain an equilibrium objectively, it should simultaneously be supplemented subjectively through meditation. This helps to accelerate the process of energy flow and effects are achieved or felt faster, that is to work on the horizontal axis as well as vertical axis and the resultant is what we experience .

In following the tenets of Vaastu, we are trying to overcome mental discomfort and attain peace of mind.

With Vaastu , we are not changing our destiny. We are only trying to smoothen our lives. Destiny always prevails. But by using remedial measures as provided by Vaastu, one can reduce the difficulties of one's life.



The diagram indicates how Vaastu affects us in day to day life.

The destiny of each individual is predetermined by his past Karma that becomes the vehicle through which he travels his present life to reach his destiny.

The driver of the vehicle is his Action and the fuel to the vehicle is his Thought.

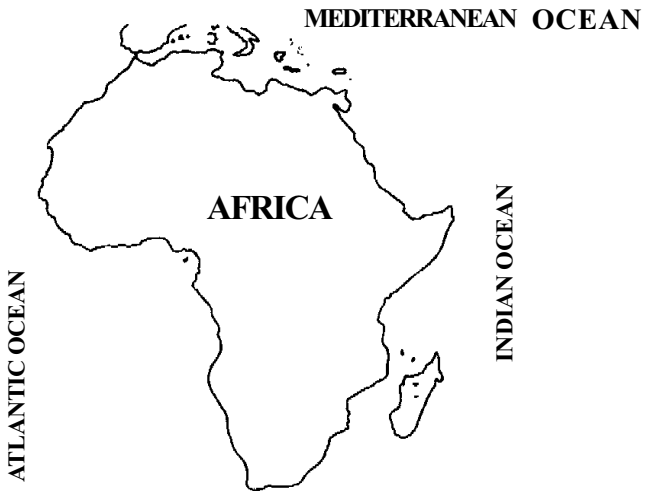
The road to destiny can be smoothened by following Vaastu or it will continue to be rough. For some the road is smooth even without knowing or following Vaastu .However , it is advisable to follow Vaastu for opening up the gates to a healthy and happy life .

\*\*\*\*\*

### **3. NATURE OF THE GLOBE AS PER VAASTU**

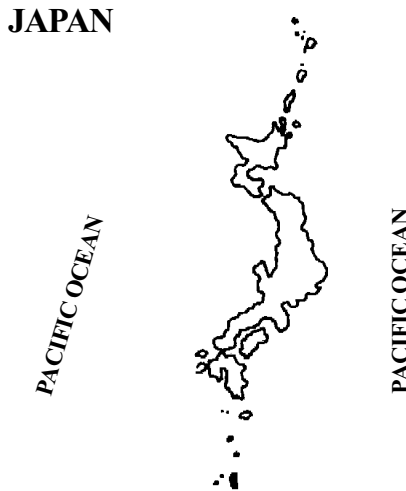
---

It is a well-known fact that 3/4th of the Globe consists of water and the remaining 1/4th earth. Some of the countries that were formed on the earth are prosperous while some others are in declining state owing to their geographical position. If we consider a country, taking it as a separate unit, we can easily understand why that country is in rising position taking into consideration its religious, social, political, industrial and economic conditions.



For example, let us have a look at the geographical position of Africa, Its North-East Portion was cut off. On the West and North-West side of the continent the extent of the land is bigger than that on the other sides. On the East of this 'Dark Continent' there is the Indian Ocean, on the North there is the Mediterranean Sea

and on the West the Atlantic Ocean. If the rules of 'VAASTU' are applied to this continent, it is evident that the position of the land is quite erroneous. The whole world knows the ultimate result of this irregular position. There have always been civil wars, ethnical feuds and famine stricken troubles. The people were treated as slaves by the white race for a long time, they were thirsty of blood.



If you look at Japan, you will have a different picture of the islands. It is a developed country. It was developed in a short period, sustaining the on slaughters of the Second World War. It is in the "Land of the Rising Sun." Though the area of the islands is not much, yet its all-round growth is praise worthy. The reason for such growth is only its Geographical position. There is the pacific Ocean on the East and North-East of the Islands. They are surrounded by water on the West and South East. This is the reason why Hiroshima and Nagasaki were much affected by the Bomb attacks during the Second World War, as a result of which, they were destroyed. Besides facing the havoc, there



is the danger of frequent earthquakes in this country. This is owing to the water flowing on the South-Eastern Side.

**ENGLAND**



There is Britain which used to claim that “The Sun never sets on the British Empire.” Everybody knows that the British culture, civilization, industrial development, political strategy, religious supremacy the popularity of the English language are seen, even today in each and every country in the world. The extent of this country is less; but its dominating power cannot be questioned. The reason for this importance is the Atlantic Ocean on the West, the North Sea spreading upto the Arctic Ocean is on the North. That is why this little country was able to lord over the whole world.



Now, we shall have a glance at our Motherland, India. When we read the History of our country, we find how big Empires rose and how they fell down. There were many attacks on this country by foreigners who plundered the country many a time. It is only the Geographical position of this country which made her subordinate to the alien powers.

There is the Bay of Bengal on the East, the Indian Ocean on the South and the Arabian Sea on the West. It is surrounded by water on the South-East and South-West sides also. It is only owing to this reason that India became often a target of the foreign attacks. Of course, there are the Himalayas on the north of this Peninsula. The Himalayas, with its pristine glory, is called the King of the Mountains. A good feature in the Geographical position of this country is that it is a little bit bent towards East. This is the only reason for which our country dominates, even today, the whole world in religious, cultural, literary as well as philosophical field.

Keeping in view the Geographical position of India, those who want to construct buildings, have to follow the principles laid down in the 'Vaastu-Shastra' verbatim, so that the owner of the building might escape from evil powers.



If we look at the map of Russia, we find that the land on the West is more extensive than that on the East. There is the Caspian Sea on the South-East side and Black-Sea on the South. Therefore the water on the South-East is balanced with that on the North-East side. Owing to this position, the people of Russia had to face untold difficulties during the reign of the Czar and later on under the Communist Administration. It is also well-known thing that the Russian suffered a lot during the Second World War.

So, to sum up, one should know that the influence of water is seen on the countries which are surrounded by it.

\*\*\*\*\*

## 4. THE BIRTH OF VAASTU PURUSHA

---

---

Vaastu Purush is present in each and every plot whether it is big or small. He has a fixed and peculiar body. His head remains hanging down and his body is spread all over the length and breadth of the ground. There is an interesting story in the MATSYA PURAN in which the birth of Vaastu Purusha is narrated. By reading that story one knows why the worship of the Vaastu Purusha is necessary before beginning construction of any building.

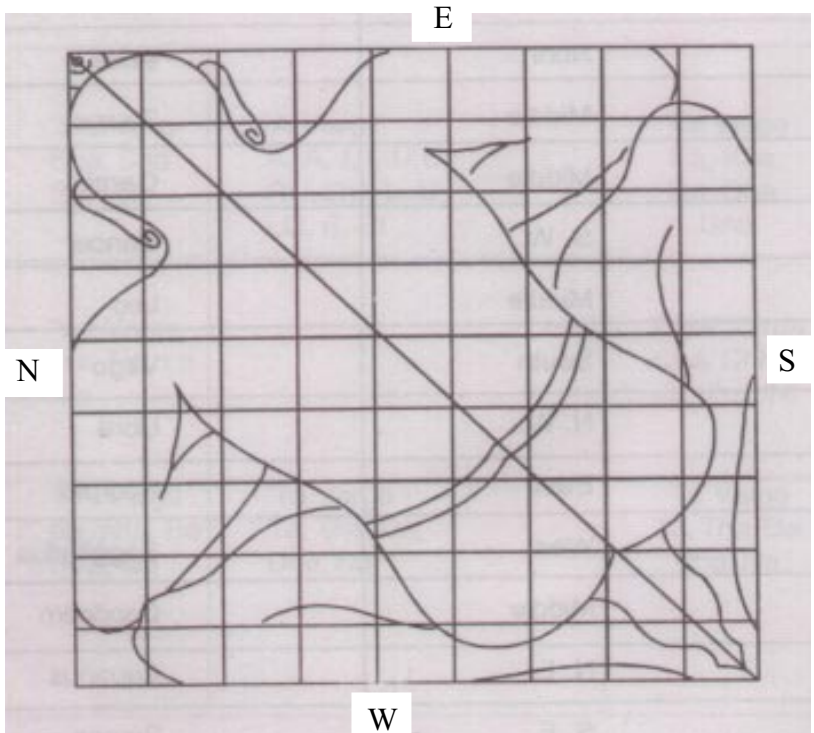
Long long ago Lord Shiva fought against the demon named ANDHAKA and killed him. While fighting with demon, Shiva was very much tired and began to sweat profusely. A man was born of the drops of Shiva's sweat. He looked very cruel. He was very hungry. So he began to make penance to appease Lord Shiva and get a boon from him. Shiva was pleased with his penance and appeared before him. The devotee prayed to Shiva, "Oh Lord! Please permit me to eat away all the three worlds." Shiva said, "Let it be so." The devotee's joy knew no bounds. He got possession on all the three worlds and first he was ready to eat the terrestrial world (Bhooloka). Then the celestial (Devatas), Brahma, Shiva and the demons (Rakshasas) also were terrified and caught hold of the devotee encircling him.

Vaastu Purusha, being arrested like this, said to the Gods, "Oh, Celestial Beings! You have all caught hold

of me and tied me on all the sides. How long shall I be like this, in this position hanging my head down like a prisoner? What shall I eat? Listening to those words, the celestial beings said, “Today is Bhadrapada Shukla Triteya Saturday and ‘Visakha Star’; So you lie down here on the ground changing your position once in three months, i.e. from ‘Bhadraspada’ to ‘kartik’ you lie down putting your head in the eastern direction and your feet towards the west. During the months of “Margashira”, ‘Pusham’ and ‘Magha’, you lie down towards the south looking towards the west and put your feet towards the north during the months of ‘Phalgun’, ‘Chaitra’ and ‘Vaisakh’ put your head towards the west and feet towards the east., looking towards the north; in the months of ‘Jyestha’, ‘Ashadha’ and ‘Sravana’, put your head towards the east. North and the feet towards the south & look towards the east. Whatever side you may turn, you will have to lie down on the left side only. You will be known as ‘VAASTU PURUSHA’. You will tease the people, to your heart’s content, who construct buildings and temples, dig wells and tanks on the side towards which you see and in the direction towards which you hold your feet. You may trouble and even devour those people who construct the aforesaid buildings and temples etc. In the direction where you lay your head and back and those who lay foundation-stone without worshipping you or without satisfying you with “Homa” and the like. Then the Vaastu-Purusha was quite satisfied. Since then the worship of Vaastu-Purusha has been in vogue and it has become compulsory for those who want to construct any kind of building.

Forty-five celestial beings, out of whom 32 from without and 13 from within caught hold of the devotee. The thirty two celestial beings are :-

- (1) ISH (2) PARJANYA (3) JAYANT (4) INDRA (5) SURYA (6) SADYA (7) BARISHAM (8) AKASH (9) AGNI (10) PUSHNA (11) VITATHA (12) YAMA (13) KRITANTA (14) GANDHARVA (15) BRINGAVAJA (16) MRIGA (17) PITATRA (18) DAREPALE (19) SUGRIVA (20) PUSHPADANATA (21) VARUNA (22) DATIYA (23) SESA (24) YAKSHMA (25) ROGA (26) NAGA (27) MUKHYA (28) BHALLATA (29) SOMA (30) SAPRA (31) ADITI and (32) DITI.



All these 32 celestial beings are out of the limits of the devotee whereas the following 13 beings are within his limits :-

(1) APA (2) SAVITA (3) INDRAJYA (4) RUDRA (5) MARICHI (6) SAVITRI (7) VIVASWAN (8) VISHNU (9) MITRA (10) RUDRA (11) PRITHVIDHARA (12) APAVATSA and (13) BRAHMA.

These celestial beings laid force on the different limbs of the devotee and sat on them as shown below :

ISH (AGNI)- head; APA-face; PRTHWI DHARA & ARYAM-chest; AVANTSA-heart; DITI & INDRA-shoulders; SURYA & SOMA-hands; RUDRA & RAJYAKSHMA -left arm; SAVITRA & SAVITA-eight arm; VIVASWAN & MITRA- stomach; PUSHA & ARYAMA-wrist; ASUR & SESA-left side; VITATHA & GRAHAKSHAT-right side; YAMA & VARUNA-thighs; GANDHRVA & PURAMADAN- on the knees; SUGRIV & BHRISH-shanks; DWARIKA & MRIGA-ankles; JAYA & SHAKRA-on the hairs grown on the feet; BRAHMA-on the heart. Being bound like that, the devotee lay down there only. Since then, he has been lying there surrounded by the celestial beings are thus he was called “the God of Vaastu or “VAASTU PURUSHA”.

\*\*\*\*\*

## 5. THE FIVE MAIN ELEMENTS

---

---

### ( PANCH MAHABHOOT )

All objects of this universe are made of five elements basically. These five basic elements are (1) Earth or Soil (2) Water (3) Fire (4) Air (5) Space ( Aakash ). These are called “ Panch Mahabhoot “.

**1. EARTH :-** Earth here means composition of the surface of the earth , the soil and other minerals present in the soil. The upper part of the surface is called soil , Stone, sand, iron, lime etc., all these are parts of soil. All these physical elements are available in limited quantity and on a particular place. This depends on the composition of surface, its form and size, trees and vegetation grown upon it etc. that whether it will be appropriate to inhabit at such a place or not . Moreover if there is a residence there , what type of construction should be there. Availability of essential building materials and their transportation also depend upon the formation of soil . Soil can be categorized on the basis of its shape , touch , taste and sound . We must take care that it suits our physique while selecting land for building and collecting building material. There are many things described in *Vaastu Shastra* about the size and type of land and method of “ *Bhoomi Poojan* “ are also explained in it .

**2. WATER :-** It is most essential for all creatures and is a basic element in construction. Water forms 3/4 part of body’s weight. All of us know about different forms and resources of water . The quantity of water available at present is limited and is less than the



requirement. Not only for creatures and vegetation but also for house construction , water is needed in sufficient quantity. Therefore , it should be ensured before house construction , whether water will remain available or not . Usually , in most of the villages a pond is available along with ground water source , which is maintained by villagers themselves . People inhabit colonies on the banks of rivers, lakes and sea, where underground water is available in large quantity and wells can be dug up in a suitable place for colonies . Shape and size of building and life-style are designed at a place according to the availability of water and relation with land. Taking care of water also means the house is stable even during heavy rains, the building is not harmed and flood does not cause havoc . Taste forms, feeling and sound are characteristics of water .

**3. FIRE :-** Fire circulates energy in the form of light and heat . The sun is the main source of light and heat for us. The movement of the earth in relation to the sun causes day and night and change in seasons . Rain and wind are also possible due to the heat of the sun. The sun provides living beings with courage, zeal and power . Most of the colonies in the world are found in temperate zones where Sun's energy is available in sufficient quantity . Care should be taken that the building has constant supply of light , it is completely safe from fire , construction material is selected in such a way that it is fit for living comfortably in both seasons - in summer as well as in winter and it is not destroyed by lightning. Thus house construction plan is greatly affected by heat and light ( i.e. Fire ). Shape , feeling and sound are characteristics of fire .

**4. AIR :-** Atmosphere ( i.e. mixture of gases like Oxygen , Nitrogen, Carbon dioxide, Ozone etc. .) exists around the earth up to 400 km height approximately. Composition of atmosphere and presence of vapours in it differ from place to place according to local situations . We cannot see air but we can feel and hear it. Air is an essential element for all living beings. It is essential to have correct supply , correct temperature and pressure, correct percentage of humidity in the air for both kinds of comforts- physical and mental- for man. Therefore, the shape, size, construction and direction of buildings should be such as they have sufficient supply of air for healthy and comfortable living. No part of the building should remain without air . Foul air should not gather in the building and fresh air should come continuously . From which direction air should enter or not is also important . In our country the air blowing from the South is considered baneful and inauspicious.

**5. Space :-** Space is the most widely spread over of the five basic elements. The unending region of the universe in which all the heavenly bodies exist is called space ( Aakaash ). There is no place in the universe where this space does not exist. Gravitational pull of various heavenly bodies, magnetic power, different kinds of radiations and waves like ultra -violet rays, infra- red rays, light rays , cosmic rays, etc. are always present in space. Their effects can be felt in many forms, and many activities and designs ( plans ) in our life are conducted by their effects .Sound is produced in space only. If there is no space, sound waves are not possible. The form in which space permits the building will decide accordingly the form of our talking, singing and playing, weeping and other activities. The echo of our sound will go according to space. Therefore, the houses should be built in such a way

and plan that these invisible forces of nature and the energies generated by them can be fully utilized and their harmful effects can be avoided.

Human body is also made of five basic elements and similarly all the other things of the world are made of them. Therefore, the five basic elements existing inside and outside man have a constant though invisible relation which affects activities of life. In our residence or office buildings, etc., are constructed in a well- planned manner keeping in view the effects of “ Panchmahabhoot”, i.e. the five basic elements - earth, water, air, space and fire- life can be full of more happiness and prosperity.

The ancient *Rishis* and Sages had knowledge of the relation between five basic elements and their energies and their utility in needed quantity. Therefore, *vaastu shastra* explains such principles of house building according to which appropriate use of the effects of these five basic elements can be achieved by selecting land accordingly, as soil inhabits our body, similarly our body inhabits a building. The effects of these five basic elements have been fully taken care of in the principles laid down in Vaastu Shastra, by which a residence can be made for a comfortable life and not merely for show.

\*\*\*\*\*

## 6. SCIENTIFIC VAASTU

---

### **Vaastu Shastra & Astronomy**

Before the discovery of magnetic compass, ancient cultures had always used heavenly bodies and astronomical observation for locating directions. From the heavenly bodies these cultures derived their cosmic view of life. Vaastu Shastra is a study by ancient Chinese, Egyptian and Mayan cultures to understand the true significance of the sun, the moon, the planets and the stars in terms of cosmic energy fields and cosmic forces at play and the resultant micro-effects on nature and human life. The rules of Vaastu Shastra were evolved out of cosmic humanitarian outlook that sought to ensure a harmonious life in tune with nature and the cosmos for the entire mankind.

### **Vaastu Shastra and Astrology**

Astrology predicts the future on the basis of strengths and deficiencies in any given horoscope. Astrological inferences are based on the relative and the combined force-fields of the planets acting on an individual consciousness. Position of planets in a particular direction have an effective and definite control on human endeavour and future events since it is the combination of various gravitational and allied forces, that gives rise to a particular situation.

In the same way, a house built on a particular plot has direct correlation with the electromagnetic forces and

the gravitational fields of earth and other planets together with effects of cosmic origin. Understanding of these forces and energy fields counterbalance by gravitational mass to attain dynamic balance, it is the basic philosophy of Vaastu Shastra.

### **Vaastu Purush Mandal :-**

In Vaastu Purush Mandal, two sources of energies or cosmic forces are designated by symbolic nomenclature which refers to the positive or negative influence of these forces; leading to positive, comfortable and lively results, or negative retrograde and destructive results. It is symbolized by the names of deities ruling various directions in Vaastu Purush Mandal. In the ancient text, the positive influence is termed as (Priti Sangam) indicating dynamic additive flow of both the forces in the direction of propagation, while the negative influence is termed as (Visha Sanchar) meaning thereby that the forces are turbulent and flow in opposite directions to each other trying to annihilate the other force. The two sources of force and energy filled are :

- (1) Solar energy termed as (*Pranic*) energy or the cosmic energy and
- (2) Electromagnetic flux termed as (*Jaivic*) energy or the organic energy.

***Pranic*** or the solar force field can be represented as an ever changing dynamic sector referenced to solar position and moves through 360 degrees in relation to the earth's position. On the other hand, ***Jaivic*** or organic force field is unidirectional with sectors directed from North to South poles. Friendship, reinforcement or union of these forces is ideal heavenly' condition. Oneness of Pran and Jeev is

termed as life. Any inimical or contradictory association of these forces results in pain, hardship or sorrow. **Jeev devoid of Pran is termed as death.**

## ***Vaastu Purush Mandal and Modern Science***

Darshanshastra is the outcome of comprehensive perception of nature. Logical statements may fail to match the reality, but not perception. Comprehensive perception is the expression of reality manifested through oneness of observer, observed and observation. In man's quest for truth, Darshanshastra leaves the 'cause-effect relationship' way behind in terms of the contents and the results. It is the expression of order of nature and not to the manipulation of a clever mind. The perception of evolving after dismantling ethos based on stereotypes and categorization, is also termed as bliss.

## ***Darshanshastra***

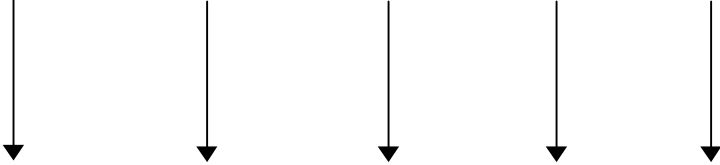
Darshanshastra Explains and narrates the state of human existence as a stream of consciousness defined as (*Satchit- Ananda*). The term freedom is inadequate here, as it projects an image of shackled human being.

# DARSHAN SHASTRA

## Upangas ( Sub-branches)

**SANGEET JYOTIS AYURVEDA YOGA VAASTU**

**Music (Astrology) (Medicine)**



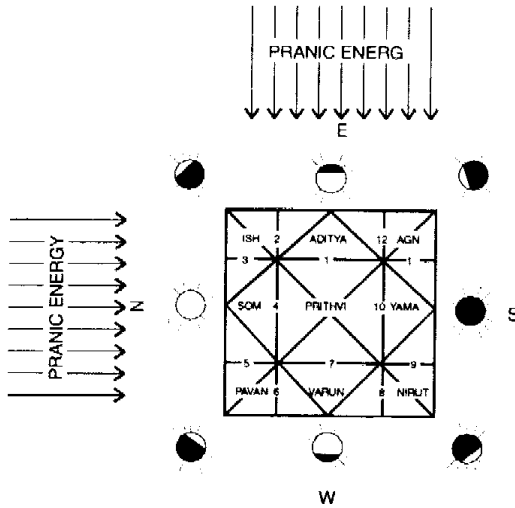
<b>Notes</b>	<b>Yoga Nadi</b>	<b>Pran</b>	<b>Prithvi</b>	
<b>Beats</b>	<b>Muhurta</b>	<b>Sama-Usha</b>	<b>Mudra</b>	<b>Sun</b>
<b>Rhythm</b>	<b>Energy</b>	<b>Sheet-Tap</b>	<b>Vayu</b>	<b>Vayu</b>
				<b>Water</b>
				<b>Sky</b>

These elements create the energy fields for existence, evolution and development of life. The branches of Darshanshastra prepare the fertile ground for the seed of *Satchit-Ananda* to flower and evolve into a lifelong experience.

The Vaastu Purush Mandal can be interpreted in terms of two scientific concepts :

- (1)** Analysis of changing directional solar energy flux super imposed on North-South geomagnetic flux and the resultant energy fields.
- (2)** Interaction of elementary particle flux with North-South electromagnetic field lines.

The term *Jaivic Urja* (organic energy) in ancient scripts refers to the North-South geomagnetic flux. These field lines orient and fix energy centres in living organism. This eternal flow defines, propagates and directs the ‘existence’ at a cellular level in all living entities. The Pranic Urja (Cosmic energy) refers to highly energetic solar energy flux, the intensity of which varies with the relative position of sun with respect to the earth.



The dark portion of the solar disk indicates the relative intensity of solar flux received by the earth, i.e., from the South direction the earth receives the maximum amount of solar energy.

The ‘deities’ governing various directions in Vaastu-Purush-Mandal denote the positive or negative confluence of the *Jaivic Urja* and *Pranic Urja* fluxes brought about by changing position of the sun in its daily journey through the sky.

The South-East (Agni), South (Yama) and South-West (Gagan) are mythologically represented as (Shiv-Tandav) or the demonic dance. The North (*Som*), North-



East (*Ish*) and East (*Aditya*) are represented as (*Chid-Vilas*), or the mind-play. As such, **the North-East is termed as the source of all energies and the South-West is termed as the sink of all the energies.** The sector connecting North-East to South-West is assumed to be the Life-diagonal or the Energy-diagonal defining the borderline between the zones of good effects and bad effects.

## **Scientific Explanation of Vaastu Purush Mandal**

The gods assigned to particular directions, and names signifying their characteristics are essentially the different images and projections of the sun and the moon in their daily traverse through the sky.

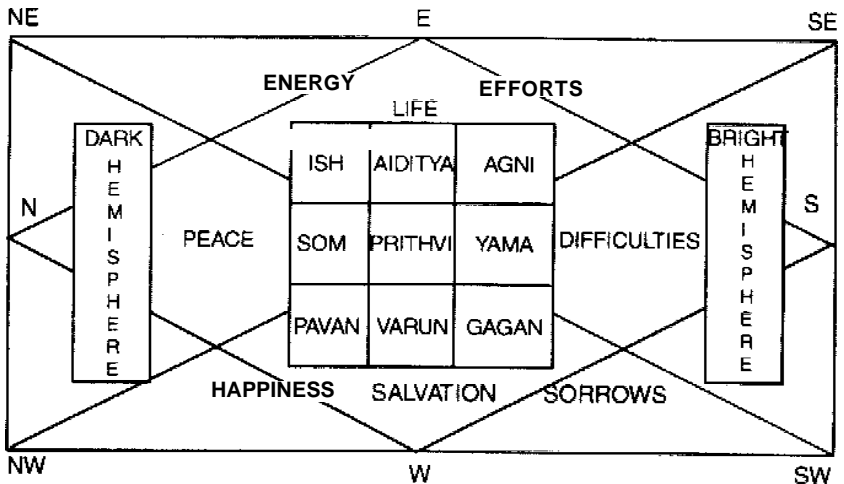
East-South-West is considered as the solar kingdom and West-North-East is called the lunar kingdom. During sunrise, for the first 2- 2.5 hours, the sun provides energy for promotion of life. It lies in the East direction and its primary energies are good for existence of all life-forms. The next three hours it starts radiating more and more energy in the environment and is called the state of *Agni* (fire). This is the time when it starts moving on its mission gradually, providing negative effects. During this period the sun lies in the South-East zone. The next three hours, in its third phase, a complete glow and aura of the sun starts coming out with its full force and energy. This is called *Yama* - a scorching and devastating state of sun. During this period, the sun lies exactly above the head i.e. in South-mid-horizon. This is the reason why the South is called the direction of *Yama* (Lord of death). After giving out all its radiation, the following three hours the sun rules over the entire horizon with its complete command.

This is called *Gagan*, a state associated with sorrow due to sun's access thermal activity and its location in the South-West. At sunset it cools down and directs its rays towards the moon for its night-reign.

**(E)**

	<b>ISH</b> (Spirit)	<b>ADITYA</b> (Life)	<b>AGNI</b> (Efforts)	
<b>(N)</b>	<b>SOM</b> (Peace)	<b>PRITHVI</b> (Still)	<b>YAMA</b> (Pain)	<b>(S)</b>
	<b>PAVAN</b> (Happiness)	<b>VARUN</b> (Salvation)	<b>GAGAN</b> (Sorrow)	
		<b>(W)</b>		

**Deities governing eight directions in Vaastu Purush Mandal**



A similar but positive pattern of cosmic reality is seen in the half circle of the moon travel and accordingly, images of goddess are assigned to the particular direction in Vaastu Purush Mandal.

\*\*\*\*\*

## 7. WHETHER THE SCIENCE OF VAASTU IS BELIEVABLE?

---

---

Before discussing the issue whether the science of Vaastu is believable or not, let us examine the characteristics of a science. Science is a creative and cumulative record of observations and experiences based on original facts of truth; to read, to experiment and to practise. That is why sciences are to be experimented and practised, not just read and lodged.

***Characteristics of a Science*** : Any science possesses the following characteristics.

1. **Rational** : Based on cause and effect.
2. **Practicable** : Capable of being put into practice.
3. **Permanent** : Not bound by the barriers of time.
4. **Normative: Codified** and governed by principles.
5. **Utilitarian** : Useful to the society.
6. **Universal** : Acceptable and accessible to one and all.

Let us see whether Vaastu, has got all the above mentioned characteristics, so as to be termed as a science.

**1. Rational** : Vaastu is a systematic study of the geological impact of the rays of sun on earth. The geological conditions caused by the above impact, prove to be congenial for the construction of an ideal house. The above fact is amply proved by the fact that the residents of the houses possessing projections

towards east, north and northeast tend to lead prosperous lives, while the residents of houses having wells or pits in Southeast, Southwest and Northwest often face worries and troubles. Since Vaastu reads the characteristics of the houses and explains their effects on the inhabitants in a scientific manner, we can undoubtedly say Vaastu is a science.

**2. Practicable :** Vaastu is practicable, as it is capable of being experimented. Those who want to construct a house, can follow the characteristics of an ideal house prescribed by Vaastu and lead carefree, happy lives there in. What all they have to do is, to follow the guidelines prescribed by Vaastu, in providing doors, windows, earth, well bathroom and toilets. Further, the above characteristics can be utilised for rectifying the existing houses, which are not built as per Vaastu and reap the advantages.

**3. Permanent :** The effect of Vaastu is permanent. This is also, because of the binding between the Earth and the Vaastu. The earth has been revolving around the sun, in a geostationary orbit for over 460 crore years. Its due to and into it the magnetic effect caused by its rotation. Due to the magnetic properties of earth, the magnetic needle of a compass always tends towards north. Since Vaastu is based on the permanent property of the earth, the effect of the principles of Vaastu also becomes permanent.

**4. Normative :** Vaastu prescribes certain rules and regulations, which are governed by the principles based on geological conditions and the inalienable properties of the earth. For instance, sinking of a well in North-East, elevation of plot in South, are the norms prescribed by the Science of Vaastu.

**5. Utilitarian :** Any science which is not beneficial to the humanity, becomes useless. Man continues to work for the invention of the items, which render his life happier and happiest. Similarly, the sole aim of Vaastu happens to be to make the lives of the individuals on earth, more and more comfortable, through habitability.

**6. Universal :** The genesis of the science of Vaastu lies in the tie between the earth and the sun. Since these two planets are of universal nature i.e. beyond religion, caste, nationality etc., the science of Vaastu which studies their impact on human beings also becomes universal.

Since Vaastu possesses all the aforesaid essential characteristics of a science, it can very well be termed as a science.

Science is an ocean and research is the exploration of that ocean to find out the hidden treasures of facts. Placing barriers -of any kind, on a developing science, is totally unwanted. Occult sciences like Astrology, Palmistry, Numerology, to some extent, can prognosticate the future of an individual but cannot change his destiny. Similarly the fate of a man cannot be altered by using talismans, or, by pacifying the baneful planets through offerings. But construction of houses as per Vasstu or altering the existing ones to suit the norms of Vaastu, are much more easier methods to pave way for a happy living.

A house constructed as per the principles of Vaastu will definitely yield good results and leads to the happy

living of the inhabitant, while a house built casually without following the tenets of Vaastu, results in a great misery and unhappiness to the inhabitant. Since the science of Vaastu is secular and universal, it does not distinguish between the users according to their caste and creed. Just as light, heat, space, water and nature do not place any restriction on their users according to their caste and creed; since the fire burns the Brahmin and Chandala, equally, the science of Vaastu also, throws open its tenets to the humanity at large, to be utilized without any distinction of caste and creed. That being the case question "whether the science of Vaastu is believable", is well answered, because of its universal efficacy.

\*\*\*\*\*

## 8. DIRECTION ACCORDING TO ZODIAC SIGN

---

---

Unsuitable directions to live according to the signs of Zodiac. Those who are indicated in the directions have no sufficient strength-

<b>N.E.</b> <b>Aquarius</b>	<b>EAST</b> <b>Scorpio</b>	<b>S.E.</b> <b>Pisces</b>
<b>NORTH</b> <b>Aries</b>	<b>In the middle of SOUTH</b> <b>the village Taurus,</b> <b>Leo, Capricorn,</b> <b>Gemini</b>	<b>Virgo</b>
<b>N.W.</b> <b>Libra</b>	<b>WEST</b> <b>Sagittarius</b>	<b>S.W.</b> <b>Cancer</b>

Varga-Chakra' according to Vashik, Narada, Kashyap and others and Chintamani Karak. These are the suitable directions to live with strength.

'Sha' Varg Sha, Sha Sa, Ha	'A' Varga A, A, I, i, U, U RU, RU, L, U, LU, E, EI	'Ka' varga Ka, Kha, Ga, Gha, Gna
'Ya' Varga Ya, Ra, La, Va		'CHA' Varga Cha, Chha, Ja, Jha, INI
'PA' Varga pa, pha, Ba, Bha, Ma Na	'Ta' Varga Ta, Tha, Da, Dha, (ॢ) Dha,	'Ta' Varga Ta, Tha, DA, Na (ॣ)

'Griharvan-Chakra' according to 'Varga'

	<b>EAST-HOUSE</b> 'A', 'KA' Varga	
<b>NORTH-HOUSE</b>		<b>SOUTH-HOUSE</b>
'YA', 'Sha' Varga		'CHA', 'TA' Varga
	'TA', 'AP' Varga <b>WEST-HOUSE</b>	



There are directions (Dig-Bhag) where the people belonging to the twelve signs of Zodiac (Rasi) should not live in any village.

<b>Unsuitable directions to live in</b>	<b>Signs of Zodiac</b>
North	Aries
Middle	Taurus
Middle	Gemini
S.W.	Cancer
Middle	Leo
South	Virgo
N.W.	Libra
East	Scorpio
West	Sagittarius
Middle	Capricorn
N.E.	Aquarius
S.E.	Pisces

## EXPLANATION FOR THE GROUPS IN ALPHABETICAL (AKARADI) ORDER

**Shloka : Akaradishu Vargeshu Dikshu Poorvaditah  
Kramat Gaja Marjata Simhaswa Sarpashu Mriga  
Shashakah Digvarganamiyam  
Yonisswavagatpanchamo Ripuh Ripuh Vargam  
Parityajya Shesha Vargashubha Pradah Astha  
Varga Akaradya Poorvadishthanamashritah.**

The substance of the above shlokas is explained below :

Name of the Group (Varga)	The presiding deity	Direction
1. 'A' Varg A, A, I, I, U, U, Ri, Ri, Lu, Luu, E, A1, O, AU, Am, Ah	Garutman	East
2. 'Ka' Varg Ka, Kha, Ga, Gha, Gna	Cat	South-East
3. 'Cha Varg' Cha, Cha, Ja, Jha, Ini	Lion	South
4. 'Ta' Varg Ta, Tha, Da, Dha, Na	Horse	South-West
5. 'Tha' Varg Tha, Tha, Da, Dha, Na	Snake	West

Name of the Group (Varga)	presiding deity	Direction
6. 'Pa' Varg Pa, Pha, Ba, Bha, Ma	Rat	North-West
7. 'Ya' Varg Ya, Ra, La Va	Deer	North
8. 'Sa' Varg Sa, Sha, Sa, Ha	Hare	North-East

### 1.) For those belonging to 'A' group

1. **East** - Own place, monetary benefit, benefit of much happiness and welfare.

2. **South** - A little happiness etc, financial benefit.  
**East**

3. **South** - Happiness, pleasure and joy.

3. **South** - Physical illness, worry and expenditure.  
**West**

5. **West** - Fear of enemies, humiliation.

6. **North** - Difficulties & Loss, problems, mixed  
**West** result.

7. **North** - Happiness, pleasure, profit, joy and success.

8. **North** - Death, fear, humiliation.  
**East**

## **2.) For those belonging to 'ka' group**

- 1. South** - Heaven, profitable, auspicious.  
**East**
- 2. South** - Monetary benefit, wisdom, fame.
- 3. South** - Happiness and joy, advantage of life.  
**West**
- 4. West** - Physical diseases, fear, worry (agitation).
- 5. North** - Fear from enemies, worry, professional  
**West** fear, agitation.
- 6. North** - Mixed result.
- 7. North** - Progress in luxuries and wealth, respect  
**East** in society, joy.
- 8. East** - Difficulties and loss, problems, fatal.

## **3.) For those belonging to 'Cha' Group**

- 1. South** - Own place, abundant pleasure and profit.
- 2. South** - Financial benefit, pilgrimage, meeting  
**West** friends and relatives.
- 3. West** - Extreme happiness etc.
- 4. North** - Physical illness, worry.  
**West**

**5. North** - Enmity, professional fear, monetary loss.

**6. North** - Difference of opinion, despondency.  
**East**

**7. East** - Profit, pleasure from friends, wisdom.

**8. South** - Fear from death, monetary loss.  
**East**

#### **4. For those belonging to 'Ta' group**

**1. South** - Own place, extreme profit, success.  
**West**

**2. West** - Monetary strength, happiness and joy.

**3. North** - More profits, happiness and joy,  
**West** successful.

**4. North** - Physical illness, use of medicines, enmity.

**5. North** - Place of enemies, fear, agitation.  
**East**

**6. East** - Mixed result, agitation, expenditure.

**7. South** - appropriate, welfare, prosperity, profit in  
**East** life.

**8. South** - Death, accident, cruelty.

## **5. For those belonging to 'Tha' group**

- 1. West** - Own place, success, profit, happiness.
- 2. North** - Monetary strength, respect, suitability.  
**West**
- 3. North** - Happiness, prosperity, position, fame.
- 4. North** - Mixed result, enmity, illness.  
**East**
- 5. East** - Fear from enemies, humiliation, necessary activity, business.
- 6. South** - Agitation, fear, blame  
**East**
- 7. South** - Suitable, prosperity in life, fame.
- 8. South** - Fear of the death, difficulties and loss.  
**West**

## **6. For those belonging to 'Pa' group**

- 1. North** - Own place, progress in fortune, respect  
**West** etc.
- 2. North** - Happiness, auspicious, joy.
- 3. North** - Profit, fame, more relations, success.  
**East**

**4. East** - Physical illness, agitation, medical use.

**5. South** - Fear from enemies, blame, business.

**East**

**6. South** - Enmity, illness, professional pressure, expenditure.

**7. South** - Suitable prosperity, profit, happiness.

**West**

**8. West** - Fatal, should be avoided.

### **7. For those belonging to 'Ya' group**

**1. North** - Own place, profit, happiness, success.

**2. North** - Pleasant, monetary strength.

**East**

**3. East** - mental happiness, agricultural prosperity, fame.

**4. South** - Physical illness, use of medicine, loss of health.

**East**

**5. South** - Trouble from enemies, political agitation.

**6. South** - Enmity without any cause, expenditure, agitation.

**West**

**7. West** - Abudant wealth and crop, happiness, success.

**8. North** - Fear from death, agitation. Responsible for **West** accident.

### **8. For those belonging to ‘Sha’ group**

**1. North** - Own place, successful, fame, joy.  
**East**

**2. East** - Monetary strength, success, profit.

**3. South** - Much profit, happiness and welfare, fear.  
**East**

**4. South** - Physical illness, use of medicine.

**5. South** - Fear from enemies, humiliation, monetary **West** loss.

**6. West** - Physical illness, enmity, expenditure.

**7. North** - Suitable, auspicious, happiness, joy.  
**West**

**8. North** - Death, illness, agitation.

\*\*\*\*\*



## 9. GEOPATHIC STRESS

---

---

Geopathy is a Greek word where 'Geo' means 'Earth' and 'pathos' means 'disease.

In other words it is the ill health of the earth or the ill effects of the energy which emanates from the earth at certain sites. Recent advance study & research carried out in various parts of the world have resulted in identifying geopathic stress which can result in the creation of harmful atmosphere in a building. The sick buildings syndrome which is also recognized by the World Health Organization points to the fact that illness can be due to working or staying in a sick building.

Initially, it was thought that inadequate ventilation and improper air conditioning as well as poor air quality were responsible for illness of the staff. But even after rectification of all these defects the problem in all sick buildings have not disappeared. The view is slowly gaining of around the geopathic stresses could be one of the factors resulting in imbalance in the energy field.

Geopathic stress has been accepted as a possible phenomenon and it has been acknowledged by several western thinkers that electromagnetic spectrum with the frequency of the earth waves can resonate which in turn can affect certain energy fields inside a structure which have bearing on health and happiness of an individual. The western thinkers also believe that some other types of harmful radiations can pervade the building and can cause many unexplained diseases including Cancer.

The work on geopathic stress was first started in 1920 by Winner and Melser in Germany. A link between cancer and geopathic zones was established by a study conducted on thousands of inhabitants. Several scientists have taken study of geopathic stress in Germany and France. Geopathic stress or the earth energy is believed to come from several sources like the earth's magnetic field radiation forces created due to movement of plates inside earth, forces due to flow of underground streams and so on. It can occur in any building irrespective of its use. It is believed it can affect plants and animals also. Similarly, modernization which has brought in tremendous amount of electromagnetic spectrum in the form of microwaves and other electronic transfer mediums have contributed to geopathic stress.

It was Dr. Manfred Curry who first hypothesized that there is a grid network of electrically charged lines of natural origin which encompasses the globe. These lines are flowing from northeast to southwest and southeast to northwest at approximately 3 meters distance. Curry hypothesized that where the lines cross, there is a double positive or a double negative energy which can disturb the balance in a human body. The studies of Dr. Curry show that people who slept on positively charged ports got cancer and those who slept on negatively charged ports got inflammatory diseases. Dr. Curry recommended that for best health one should sleep within the grid.

Dr. Hartman of Germany discovered another kind of flow of energy lines which were running from north to south and east to west. These are called as the

Hartman lines and again the study show that intersection points are dangerous for human health.

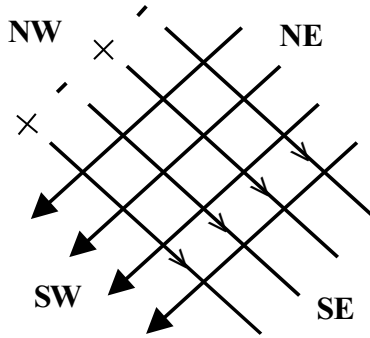


Fig : 1.

CURRY GRID : Energy waves in Northeast - South west Directions & NW -SE Directions

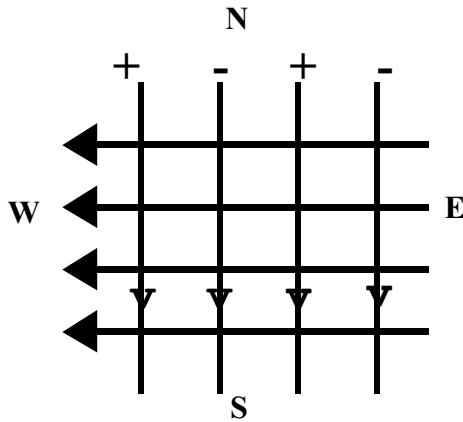


Fig :2

HARTMAN GRID : Energy rays on North -South and East -West Lines.

The super imposing of Hartman lines on the Curry lines leads to a plethora of possible errors of lines criss-crossing each other and are capable of creating ports which are potentially more powerful than those

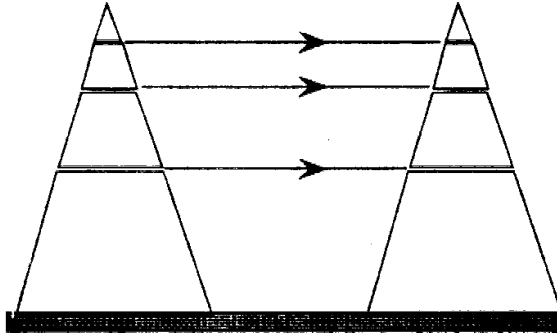
that arise from the intersection of two lines in any one of the grids. Geopathic stress always accepts that apart from the Curry and Hartman lines, spirals of energy can be emanating from a single point of the earth's periphery or from inside a building which are popularly called evolving sperm. An inward spiral can form when an energy from outside gets concentrated like for example while entering a narrow passage from a road which in turn leads to an open area. This makes the energy enter the building in a spiral form. Spirals are supposed to occur in pairs and a spiral when suspected can be corrected by using copper tube pyramids.

Geopathic practitioners also believe that it is possible for negative energy to exist as a cloud and inadvertently it can move into a building where it is trapped. It is believed to be 10 ft. wider and most of the geopathic clouds are formed when a structure is built in a wrong manner. You should suspect a cloud formation inside your structure if there are frequent accidents either in the bathroom or on the staircases.

### **Shumann Waves**

These were discovered by professor Shumann in 1952. These waves have the same frequency as the brain waves and it is believed that these waves which occur on the surface of the earth and oscillate between the earth and the ionosphere regulate the human body mechanism. The importance of these waves have been

recognized by Nasa also. Now all manned space crafts carry Schumann Wave generators as these waves are not present in outer space to protect the health of astronauts.



*Fig :- 3*

### **Ley Lines**

Ley lines are formed when stone like structures lie in a line. Any building contains stones which have been cut, hammered, dressed etc. In this sort of handling, the stone gets charged and the structure becomes an energy centre. This energy is believed to radiate even upto 25 miles. When several structures like this are placed in a line they can form a strong energy centre with energy circulating in straight lines from one structure to other. They are called as ley lines. Ley lines can be effectively used to block negative inference entering the building when such phenomena is suspected.

On the same token dressed stone structures should never be used for dwelling purposes. A survey has revealed that people who live in dressed stones

structures probably expose themselves to a wrong energy field and they suffer from ill health and ill luck. Dressed stones give negative energy and it is best to avoid them in construction. This does not apply to facade stones. This also does not apply to foundation stones as they lay buried under the earth.

The above various types of subtle energy fields which exist can influence the functioning of an organism due to the vibrations it causes. As basically the human body is electrical in nature, and as the energy fields mentioned above are electromagnetic radiations it is reasonable to suppose that the effect propagates the organism.

However, nature builds a certain amount of immunity against these energy fields just like every human being enjoys certain amount of immunity from bacteria's and viruses. However, if the immunity system is weak then the geopathic stresses can cause illnesses and can be responsible from simple fatigue to cancer.

Thus we may have to examine a building where inhabitants are distressed from various angles to arrive at a conclusion. The first factor to analyze is from the point of your vaastu.

Some people are under the impression that it is basically the science of designing structures in accordance with the local environment. They go so far as to say that the whole subject was designed keeping the prevailing wind conditions in India to take advantage of the rain and wind directions.

This type of approach is shortsighted and any way has no relevance in modern homes where control of temperature or lighting can all be achieved artificially and equally effectively. As we all know in developed countries like USA all buildings are air conditioned with closed and sealed windows and temperature is maintained at a uniform level round the year.

What is important is to recognize that lighting and air circulation are important factors but vaastu is much than this. Unless one has an exposure to subtle energy fields and their effects, it will be impossible to appreciate vaastu.

To a certain extent we have to club fengshui and vaastu because fengshui is gadget oriented and where vaastu cannot be incorporated due to one reason or other fengshui can help.

It is quite possible that after exhausting all the tools provided in vaastu and fengshui, the building continues to cause problems and here we have to check for the geopathic stress.

Unfortunately there are no instruments to measure the geopathic stress and one has to depend on dowsing to locate points of problems. Sometimes geopathic stress solutions can be different and devices other than fengshui devices may have to be employed.

## **When to suspect geopathic stress in a structure?**

- a.** If there is palpitation or increase in the pulse rate after spending some time in a building and if pulse rate returns to normal once the person moves away from the building.
- b.** A damp smell coming from any part of the building without any evidence of dampness.
- c.** If any part of the floor feels cold compared with the rest of the building.
- d.** If cats frequent the building or come to stay there.
- e.** If bees come and start a hive.
- f.** If ants or termites make a home
- g.** A dog barking at night with no apparent reason looking in a particular direction at South or Southwest.
- h.** Frequent accidents in a particular bathroom, stairs etc.

Even if the accidents takes place in different rooms which is uncommon, you have to suspect geopathic stress clouds in the premises. Do not forget that a lingering geopathic stress can be cause of an accident out side the building.

The stress clouds are locked negatively charged energy fields. They may lock themselves in a particular point like in bathroom or over the stairs. They may also be floating round in a circle inside a building but never leaving it. In this case they can bring disease and affect one family member or the other. You can suspect a stress cloud if one misfortune be falls another or one member after another is affected in a house hold.



## **How are stress clouds created ?**

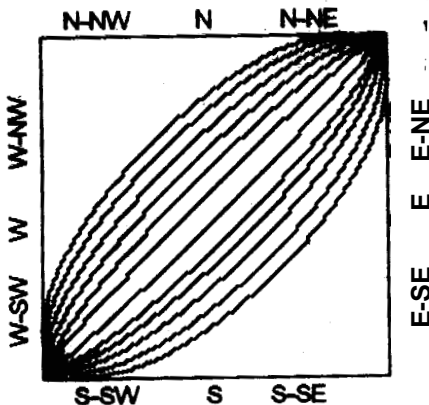
There could be several reasons. Commonly they are created by constructing a building by loading positive zones like the northeast sector first and trying to advance towards the southwest. In this case, the weakened northeast sector allows negative energy to dominate the building. Subsequently, closure of this building by construction in south and west areas locks up the excessive negative energy and creates a cloud. You will notice a lock of this energy field in two stages. Firstly the construction will get delayed, there will be cost over runs and strained relationships between the builders and the owners. Sometimes there will be accidents of working personal also.

However, there is another possibility of a negative cloud forming inside a structure. In this case a family could have lived in the structure for a number of years without any problem. The second person who occupies this structure could have the effect of the negative cloud if the earlier family had a member who was very much attached to the house and who reluctantly left it. This normally happens in case of distress sale of residential or commercial building where the owner has developed sentimental feelings for the building. The same phenomenon could also surface where an older person suffers in humiliation and dies. Note that geopathic clouds are not created when there is a suicide or violent death. It needs a continuous release of negative thought forms to form a cloud which can take several months to years. The best way to handle the geopathic stress created causing problems due to locked up negative field from these is to have a pyramids which can create a higher positive energy field inside and neutralize the negative cloud. This is a very effective and safe measure and an inexpensive one too.

\*\*\*\*\*

## 10. ENERGY LEVEL INSIDE THE PLOT

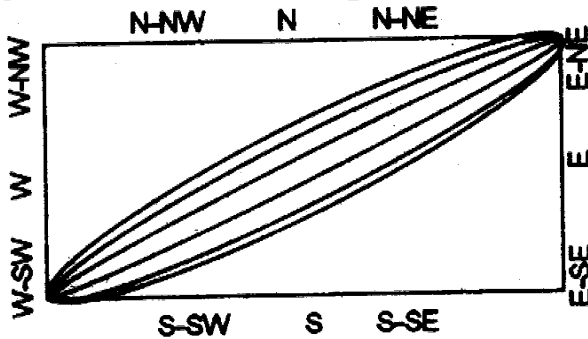
Every plot is covered with the peculiar type of energy and universal magnetic field. If there is a wall around the plot it creates an energy level and magnetic field inside the plot. If there is no compound wall the benefits of energy level and the magnetic field are not obtained. At least in the West and the South sides there should be a thick high compound wall. In the North and the East a thinner compound wall of a lesser height can serve the purpose. Instead of this if there is a wire fencing in the East and the North these directions will be open which is more beneficial.



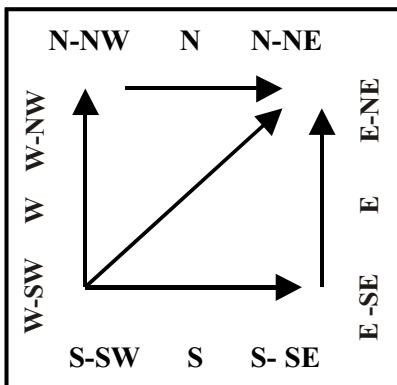
If the plot is square (length and breadth are equal) the energy level inside the plot is obtained in proper proportion beneficially.

If the plot is rectangular in shape, energy level is obtained at a medium level. Of course for travelling from the North- East to the South -West corner the energy waves have to cover more distance. Due to this intensity of the magnetic field is reduced. However if the

ratio of length and breadth is 2:1 in the rectangular plot a good magnetic field can be created. However if the length is more than double the breadth (breadth =25 Ft. length = 100 Ft. ratio = 1: 4 ) the magnetic field created is very low. In this context by raising one or two cross walls good magnetic field can be obtained. (Due to decrease in length of the plot).



The energy inside the plot flows from +ve - (that is from a higher level to a lower level). However, the South-



West corner should be at the highest and the North -East corner at the lowest level. As shown in figure if the energy level at the North-East corner is supposed to be zero than that in the North - West should exceed by one. The energy level in South -East

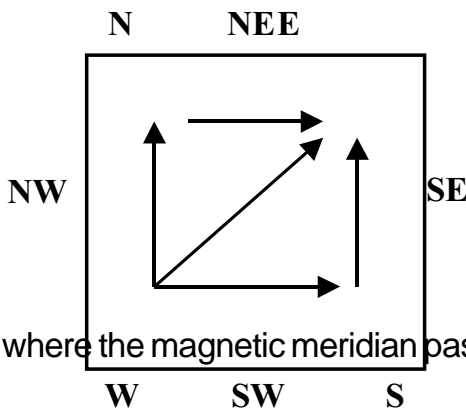
corner should exceed that in the North -East corner by two. The energy level the in the South - West corner should exceed that in the North -East corner by three.

For example : The upward slope from the North -East

corner to the North -West corner should be of one foot. The upward slope from the North - East corner to the South -East corner should be of two feet. The upward slope from the South -East corner to the South -West corner should be of one foot (here it will be  $2 + 1 = 3$  ft.).

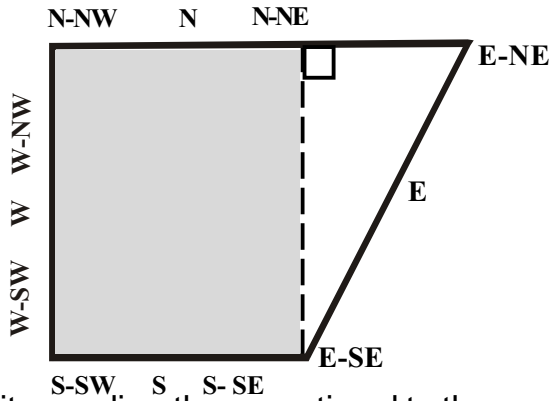
The upward slope from the North -West corner to the South -West corner should exceed by two feet i.e one + two = three.

All the above rules are applicable if the magnetic meridian (South -North direction) is passing through the centre of the plot and not through the corners of the plot. When the magnetic meridian passes through the corners of the plot the four main direction the East, the West, the North and South fall in the corner of the plot or near the corners of the plot the magnetic field and the energy level inside the plot gives medium level benefits. Of course the building built without following the rules of Vastushastra do not lead to heavy losses and the buildings built following the rules of Vastushastra give 75% benefits.

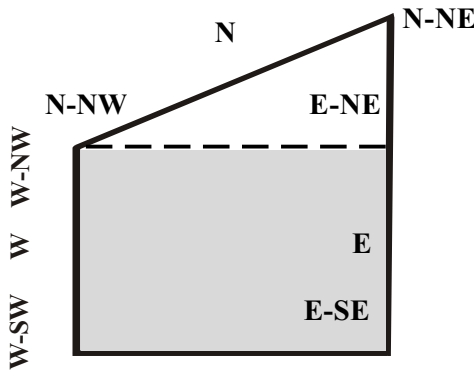


In the plots where the magnetic meridian passes through

the centre, that is the four major direction the East, the West , the North and the South meet at the centre of the plot, and the four sub-directions the North -East, the North- West, the South -East and the South -West converge in the corners of the plot, and if the North -East corner is extending (the North -East angle is an acute angle less than 90%) then the auspicious ultra-violet rays are obtained in a large measure.



The benefits are directly proportional to the acuteness of this angle (the mysterious cosmic energy is the result of the corner in the pyramids. The angle from the ground to the edge of the pyramid goes on decreasing).



Barring the North -East corner of the North -West, South

-East and the South -West corners are extended meaning there is an angle of less than  $90^{\circ}$  i.e. an acute angle in all these corners it results in losses instead of profits. It is necessary that these corners should be of  $90^{\circ}$ . Out of these only if the North -West corner is more than  $90^{\circ}$  it is beneficial. It is extremely necessary to have the South -East and the South -West corners of  $90^{\circ}$ .

For getting energy level in the plot it is necessary that the East & the North parts are vacant as much as possible. Construction in the North -East, the South -East and the North - West corners with the support of the compound walls is nothing but obstacles in the formation of energy level and universal magnetic fields. Out of these if the North-East corner is closed by constructing Garage, lumber room, Lavatory (bathroom) or any other construction with the support of the compound wall the energy level and the universal magnetic field is destroyed totally. Therefore the North -East corner should always be kept vacant and if possible there should be storage of underground water. Due to water the cosmic rays filter down to the earth which helps the building. There should not be Pipal, Audumbar or the Indian fig tree which are otherwise auspicious or any type of other trees flowers etc in the East, the North or the North-East corner because these trees absorb the auspicious ultra -violet rays by the land. The building, thus does not get the benefits of these rays. Water should be sprinkled in the East and the North sides of the plot. Due to this there is a catalytic action and the auspicious rays are absorbed by the land to a larger extent.

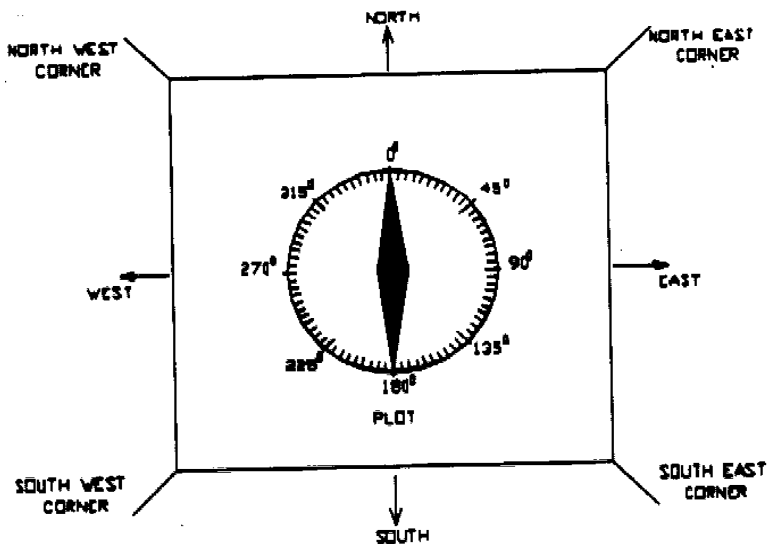
\*\*\*\*\*

## 11. DIRECTIONS HOW TO CHECK

It is now time to acquaint the students with the various directions. Most of the people find it difficult to even identify the North, South, East and West directions. To make it easier for them the following is suggested.

Stand in the centre of the plot and face the early rising Sun. You are now facing East. Raise your left arm to shoulder length. It is now pointing towards North. Raise your right arm like wise. Your right arm is now pointing towards South. Your back is where the West is.

If the road is already formed and the buildings are coming up in line with the road the above directions are sufficient to proceed further. If however the lay out is not made, or in a farm house, or in a Industrial plot one has to take the help of a Magnetic Compass.



The Compass can be a hand held one of approximately 2" dia. If you examine the compass you will find the following words marked in a circular scale graduated to 360 Degrees.

In the Compass 'N' stands for North

S-for South, E for East & W for West.

NE -stands for North East, SE for Southeast,

NW for Northwest and SW for Southwest.

Thus there are eight lines passing through the centre and the angle in between any two is exactly 45 Degrees.

## **How to use the compass to find north**

Stand approximately in the middle of the plot. Clean up an area of about 6" X 6" and level it. Take caution that there should not be any magnetic field in the centre while using compass. Place the compass on this spot. You will find that the compass has a needle at the centre, one end of which is marked in red. The needle swings and oscillates for a while before coming to rest in some particular direction. Now slowly turn the compass so that the letter marked 'N' lies right below the red marked needle. Now the needle is exactly aligned on the North South Axis and the red marked end points to the Magnetic North.

Where the road is already formed and your plot is one of the plots on the road then check whether the sides of the plot align with the magnetic axis. When you

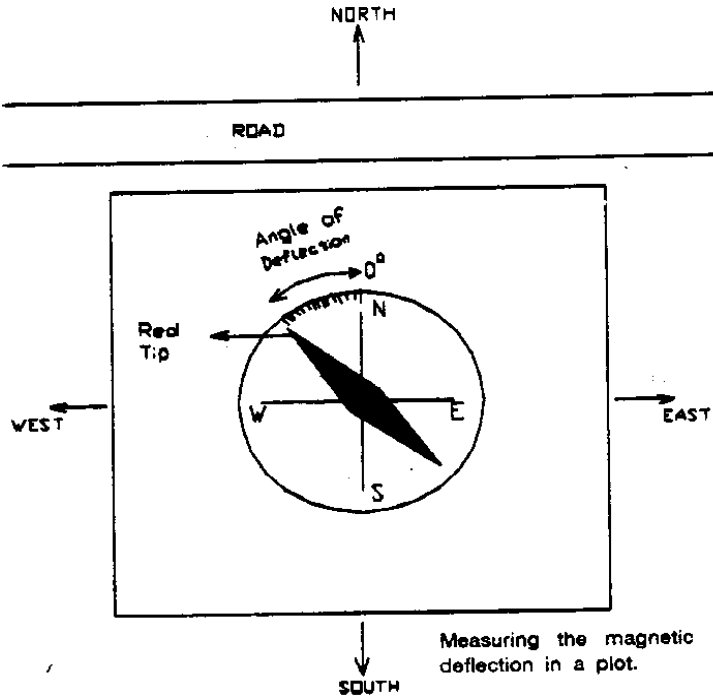


rotate the compass after the needle comes to rest and locate the magnetic North as explained above, see whether the sides of your plot are in line with the axis. If not. Rotate the compass gently so that the bisector of your plot lies on the letter 'N' the difference in degrees between the needle marked red and the letter "N" in the compass gives the deflection of the plot in degrees. If the deflection is within 10 Degrees then you may proceed as there was perfect alignment. If the deflection is very high then it is better to find the direction and zones as diagonal plots.

## **Facing of plots**

People seem to believe that East and North facing plots are auspicious and South and West facing plots are not to be preferred. This is not true. No direction is good or bad in itself. We must appreciate that for every North facing plot there will be South facing plot and for every East facing plot there will be a West facing plot. If the above assumption was true then half the residents should be in serious trouble which is not supported by facts. One should understand that the South and West plots can be made and do yield best benefits when they are exploited properly. Similarly a house built on a North or East Plot against the tenets of Vaastu will give equally disastrous results. However North & East facing plots have certain inherent advantages which is a natural characteristic of the plot. This will be missing in South and West facing plot and

will have to be put in at extra cost.



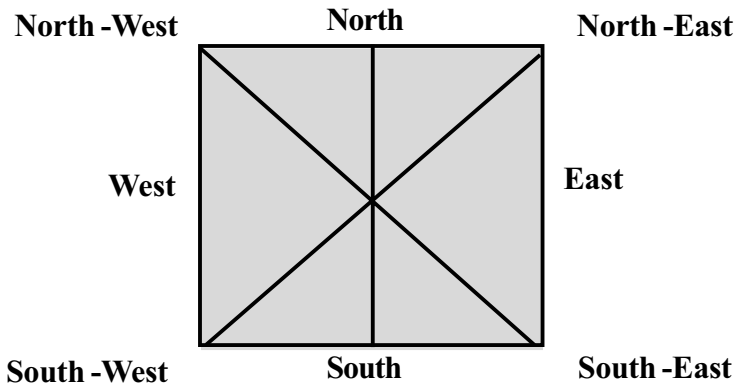
What I would like to assure you is that there is no need to get disheartened just because you are the owner of West/South facing plot.

\*\*\*\*\*

## 12. DIRECTIONS IN THE PLOT AND BUILDING

---

If we consider the curved surface of the earth as the horizontal plane, we get the four main directions. The East, The West, The North, and The South and the sub directions The South - East, The South West, The North -west and The North -East. Every direction has its own importance in *Vastushastra*. Based on these eight directions is the *Ashtaksutra* (eight principles *Vastushastra*).



### 1) *The East Direction*

The East side belongs to the Lord Indra. The sun rises from the East & this direction is given the first position. The principal God of the East direction is Lord *Indra*. It gives prosperity and wealth. In all there are none Gods (Powers in this direction). 1. *Ish (Shiva)* 2. *Parjanya (Paromeya)* 3. *Jayant* 4. *Indra* 5. The Sun 6. *Satya (Truth)* 7. *Bhrush* 8. *Akash (The Sky)* 9. *Agni (The Fire)*.

## **2) The West Direction**

The West direction belongs to the Lord Varuna who has control and power over the rain and water. The principal Gods of the West direction are 1. *Rog* (Disease) 2. *Pap* (Sin) 3. *Shesh* (Cobra) 4. *Asur* (Demon) 5. *Varun* 6. *Pushpadevta* or *Kusumdanta* (flower) 7. *Sugriv* 8. *Dwarpal* (Doorkeeper) 9. *Pitar* (Fore Fathers) Out of these Gods *Rog*, *Pap*, *Asur*, *Dwarpal* and *Pitar* are having cruel powers.

## **3) The North Direction**

The principal God of this side is Kuber who has incalculable stores of wealth and prosperity. The Gods on this side are 1. *Diti* 2. *Aditi* 3. *Sarpa* (Serpent) 4. *Som* or *Chandra* (Moon) 5. *Bhalat* 6. *Mukhya* (Main/Principal) 7. *Nag* (Cobra) All these are auspicious Gods giving happiness and prosperity.

## **4) The South Direction**

Lord *Yama* is the principal god of this direction. There are seven Gods in this direction 1. *Usha* 2. *Vitatha* 3. *Yama* 4. *Krutanta* 5. *Gandharva* 6. *Bhrungraj* 7. *Mriga*. The South direction is banned for all auspicious functions.

## **5) The South - East Direction**

This direction lies between the south and the east directions. *Agni* (fire) is the principal God of this side. This direction is used for *Hom -Havan* ( oblations by fire to a deity in a pit) and burying *Vastupurush* . The kitchen should always be in this direction.

## **6) The South -West Direction**

The corner between the South and the West direction is known as the South -West direction *Nairuti (Putna demoness)* is the authority of this direction. Therefore, it is banned for all auspicious functions. This direction should be filled with heavy unmovable goods. Pits, wells, septic tanks, water storage tank, toilets or bathrooms should not be constructed in this direction. This is because cruel forces are contaminated or get dissolved in the pits or water and it can prove harmful to man.

## **7) The North -West Direction**

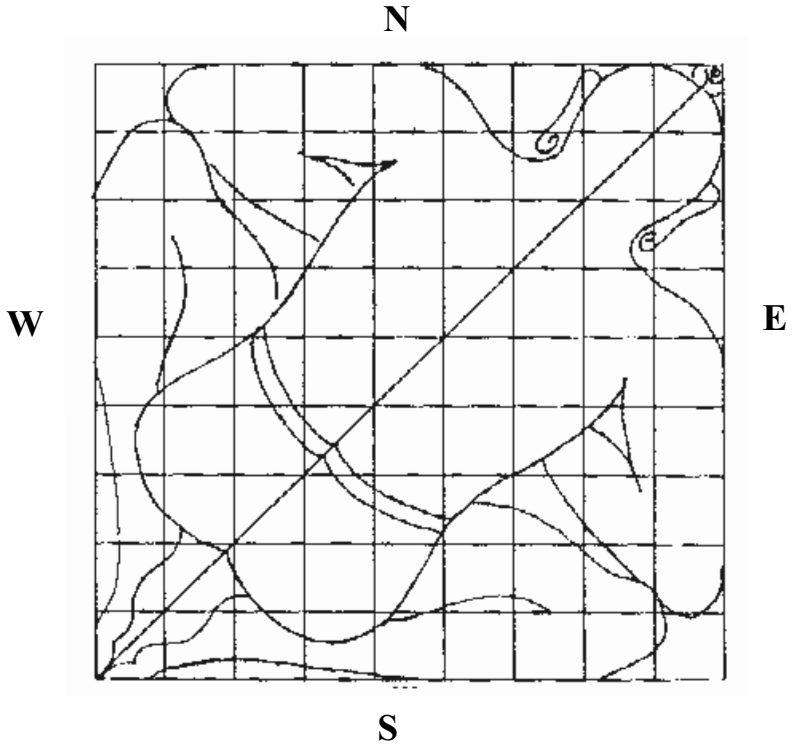
This direction is in the corner of the North and the West directions. This is the direction of *Vayu Devta* (The God of wind). Air is necessary for all living beings, therefore, tall structure should not be built in this direction. Tall trees should not be planted in this direction.

## **8) The North -East Direction**

The corner of the north and the east directions is known as the north -east direction. God himself rules this direction. Therefore, there should be no construction in this direction, toilets, sundry room etc. should not be built in this direction. However, wells, underground tanks, boring wells etc. give auspicious results, if built in this direction.

# Vastupurush

(The Deity of Edifice)



# Vastuchakra and the place of the deities

North East		The East, The God Indra (Prosperity)					South East	
1 Ish Shiki	2 Parjanya	3 Jayant	4 Indra	5 Surya	6 Satya	7 Bharush	8 Aakash	9 Agni
32 Diti	33 Up	33 Up	37 Marichi	37 Marichi	37 Marichi	34 Savita	34 Savita	10 Pusha
31 Aditi	44 Upvatsa	44 Upvatsa	37 Marichi	37 Marichi	37 Marichi	38 Savita	38 Savita	11 Vitatha
30 Rishi	43 Prithvi- dhara	43 Prithvi- dhara	45 Brahma	45 Brahma	45 Brahma	39 Vivaswan	39 Vivaswan	12 Briha kshat
29 Som	43 Prithvi- dhara	43 Prithvi- dhara	45 Brahma	45 Brahma	45 Brahma	38 Vivaswan	38 Vivaswan	13 Yama
28 Bhallat	43 Prithvi- dhara	43 Prithvi- dhara	45 Brahma	45 Brahma	45 Brahma	39 Vivaswan	39 Vivaswan	14 Gundharv
27 Mukhya	42 Ruddas	42 Ruddas	41 Mitra	41 Mitra	41 Mitra	40 Vishnu	40 Vishnu	15 Bhrig Raj
26 Nag	36 Rudra	25 Shesh	41 Mitra	41 Mitra	41 Mitra	33 Indrajay	35 Indrajay	16 Mriga
25 Rog	24 Pap	23 Shesh	22 Asur	21 Varun	20 Pushpa Devata	19 Sugriv	18 Dwarpal	17 Pitav
North West		The West, The God Varun (Rains)					South West	

The North, The God Kuber (Wealth)

The South, The God Yama (Death, Justice)

\*\*\*\*\*

## 13. SELECTION OF LAND/PLOT

---

---

For any building the land (Kshetra) is the basic requirement and utmost care must be taken in its selection. Normally an Architect or Vaastu Shilpi is brought into the scene only at the designing stage but it is advisable to involve him at the stage of buying the land itself. In selection of the land the following aspects should be taken care of :

**(1) Types of Earth :** Earth is classified according to its colour brick red, dark brown; white, red, yellow, mixed colour, black and also according to their smell, taste. Texture, etc., Black and clayey soil is not good for construction and while designing the foundation/ footings, the load bearing capacity of the soil should be ascertained. Sites with big boulders, anthills or where murder or burial has taken place and those with loose or filled -up earth should be avoided.

**(2) Location and Environment :** As far as possible the site should be level or sloping towards North and East or North-East. If it is a small one, which normally is the case in the towns or cities, there should not be any big trees like Aswatha (peepul) , Mango, Banana , Tamarind etc., whose roots and branches may cause damage to the building. If the site is big then the building area should be sufficiently away from them. Site which has fertile earth, flowering plants, fruit trees, grass etc., is good and sites without the source of ground water should be avoided. Those abutting temples, ashramas, schools, colleges,



mantapas are not advisable for obvious reasons and sites behind Vishnu temple or to the left of Durga temple are also not good and it should be atleast 50 meters away from a Shiva temple. (Any site to the South or West of hills shall be rejected, but site towards the East or North of hills should be accepted.)

**(3) Vaastu of Plots :** Levels, angles, it's size, shape etc., should be according to principles of Vaastu. In towns and cities due to various reasons the choice is limited, but as far as possible one must endeavour to acquire land adhering to Shaastras. Prevention is better than cure, is an age old saying, and instead of suffering ill effects of wrong decisions and repenting later. It is better to be alert in initial stages itself.

**(4) Shape of the Plot :** Shape of the plot plays a very vital role in the land selection. Principles of Vaastu of plots is same for houses, industries, commercial establishments, and apartments, except that the size of plot varies.

i) The plot should be a square or rectangle (ratio of width to length should not be more than 1:2 in case of rectangular plot) and the East and West dimension should be more than that of North and South, but nothing like a big site where all round open spaces could be left.

The square plot is best, but for reasons unknown, our town planners have uniformly adopted rectangular plots as the norm. A rectangle stretches the energy lines and the plot grows weaker as the length to breadth ratio increases.

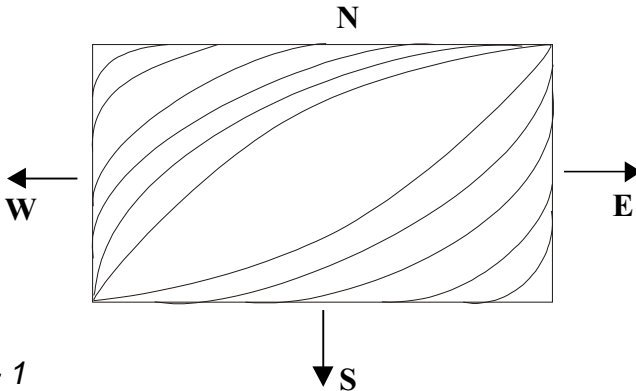
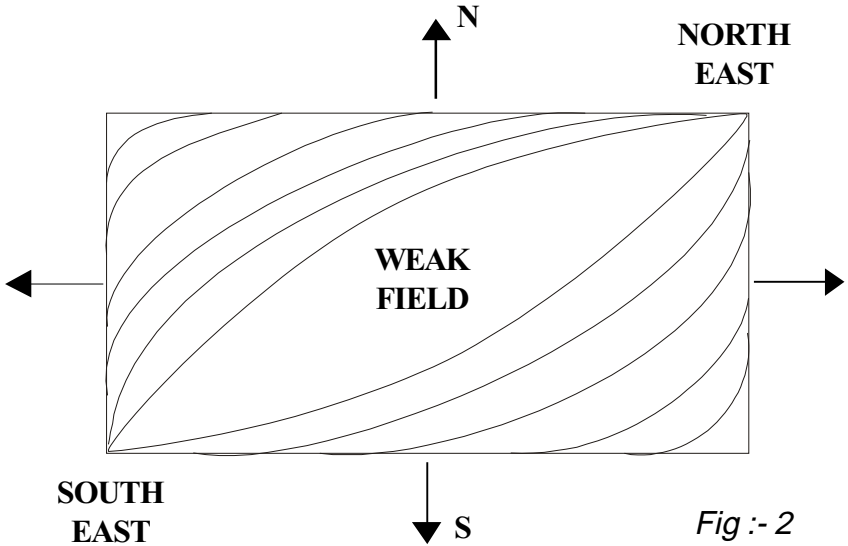


Fig :- 1

In a rectangular Plot the Energy Lines stretch themselves to meet South West Hence the field strength decreases

Normally the plots are made in sizes like 30' x 45', 40 x 60' ,60' x 90', 90' x120' etc. Although these plots are inferior to square plots we seem to have no other alternative but to make the best use of the field available. It is hoped that the town planners and housing cooperatives will take note of this and atleast in future plots are made square.

Why this obsession for a square? We all know that the energy field is best present in a pyramid whose base is square. It is this recognition that we see in the Gopurams built over the temples. They were believed to have the best geometry to tap and transmit cosmic energy. Hence the base of the Pyramid which is a square is considered best for getting maximum benefits. In rectangular shapes like 30' x120' the field is very weak and it is inadvisable to construct a single unit house in such a plot.



In an abnormally stretched plot the energy lines are stretched too much resulting in poor Vaastu field

ii) Plot having triangle and round shapes; those with five corners; those having hexagon, octagon or polygon shapes; and those with irregular and odd shapes are not good.

iii) plot in the form of 'Gomukhi' where the frontage is less than the width at the rear is good due to sentimental reasons provided the road is in the Southern and Western side only and not in Eastern and Northern sides.

iv) Site in the form of 'Vyaagramukhi' where the frontage is more than the width at the rear is not good but not in the case of roads in the Eastern and Northern sides.

v) Angle of the different corners of plot is equally important in determining the merits and demerits of the plot.

**(5) Angles of the Plot :** If all the four angles are  $90^{\circ}$  it is good. South - West angle should be close to  $90^{\circ}$  or less, but never more and this is very important. North-West angle should also be close to  $90^{\circ}$  or more but never less. North -East angle should be close to  $90^{\circ}$  or less but never more. In other words the distance from North -east corner to South -West corner should always be more than the distance from North-West corner to South - East corner.

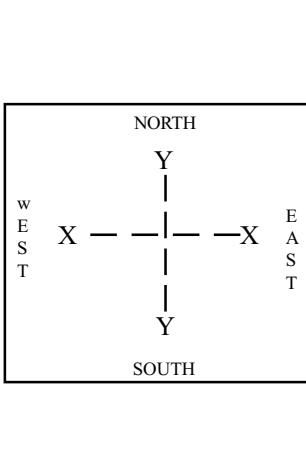
**Position of Site in Relation to Road :** Direction to which the plot is facing, i.e. the position of road (as per principles of Vaastu) determines the value of site, and those sites are termed accordingly:

- (a) East Block :** Those sites having road in Eastern side only.
- (b) South -East Block :** Those sites having roads in Eastern and Southern sides.
- (c) South Block :** Those sites with road towards South.
- (d) South - West Block :** Those sites with road towards South and West.
- (e) West Blocks :** Those sites with road towards the West.
- (f) North - West Block :** Those sites with road towards the North and West.
- (g) North Block :** Those sites with road towards the North.
- (h) North - East Block :** Those sites with roads towards the North and East.

# Land /Plot Selection

## MAGNETIC AXIS

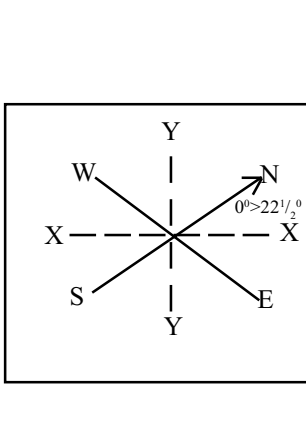
The axis of the Land/Plot should match with the magnetic axis of the earth.



The axis of the plot x - x is parallel to the East - West axis.

The axis of the plot y -y is parallel to the North - South axis.

**(Good for growth)**



The axis of the plot is not parallel to the magnetic axis and has deviation more than  $22\frac{1}{2}^{\circ}$ , the plot becomes cross axis.

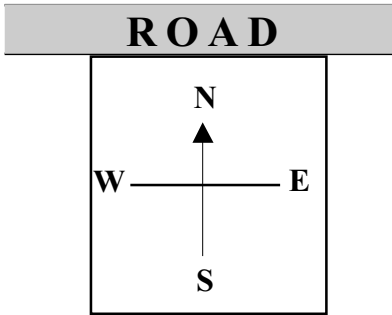
**(Prosperity, happiness and peace of mind).**

**In plot which are not parallel to magnetic axis positive effect is reduced & the vaastu correction also does not give immediate and desired results in comparison to plot having parallel axis.**

## ADJOINING ROADS

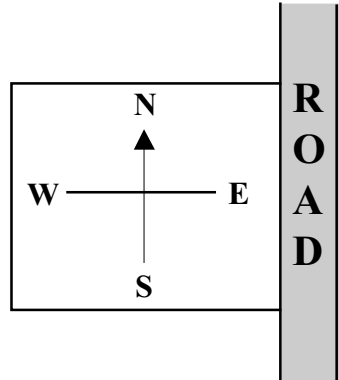
### Plot having road on one side

#### Plot facing North Road



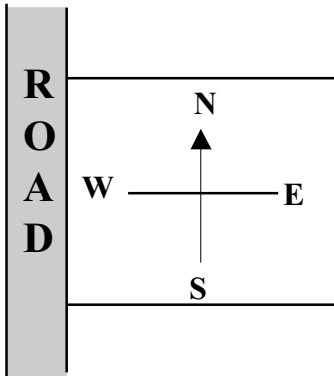
**(Bring Wealth & Prosperity)**

#### Plot facing East Road



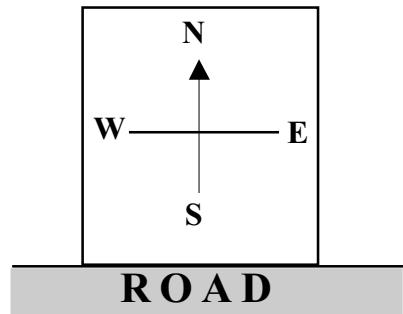
**(Bring Fame Name & Position in the Society)**

#### Plot facing West Road



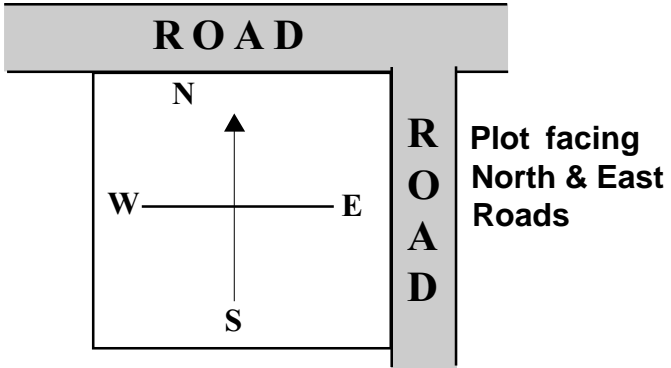
**( Average, Good for Business Concerns)**

#### Plot facing South Road



**( Good for Business Relating to Women)**

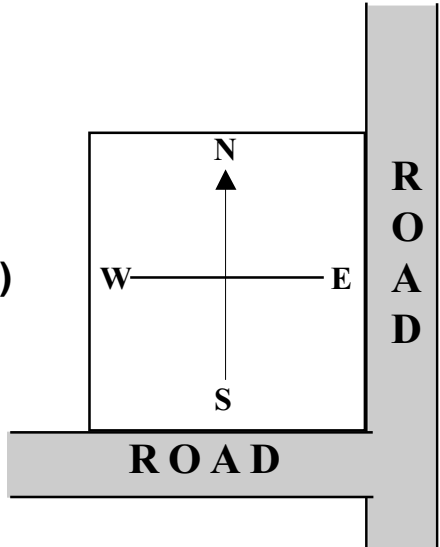
### Plot having road on two sides



**(Overall Prosperity)**

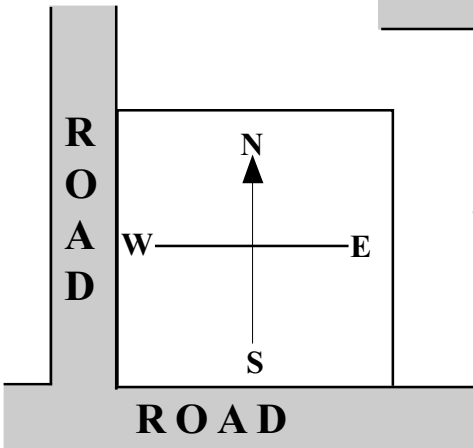
Plot facing  
East & South Roads

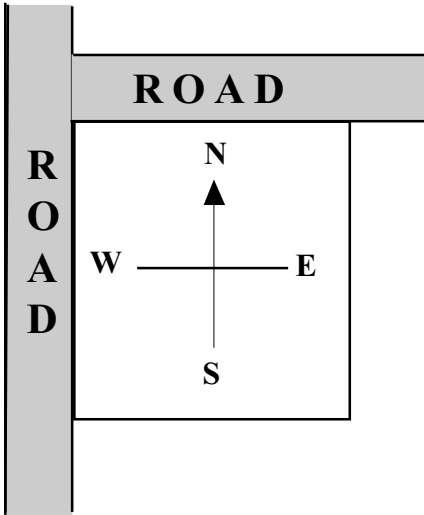
**(Good for Female)**



Plot facing  
South & West Roads

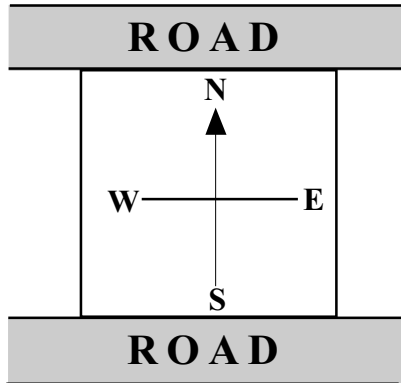
**(Average)**





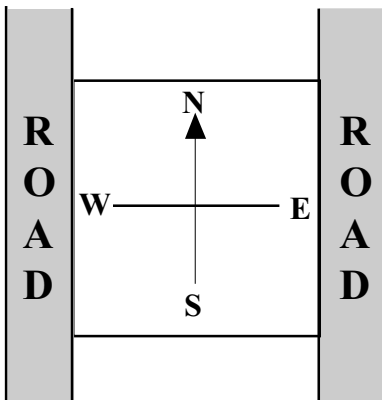
**Plot facing  
West & North Roads**

**(Good )**



**Plot facing  
North & South Roads**

**(Average)**



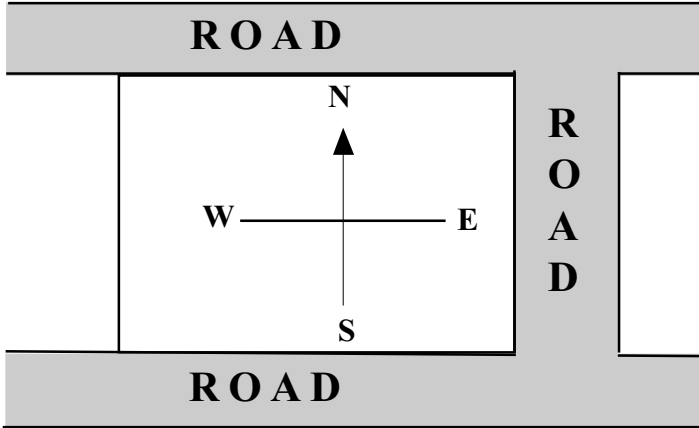
**Plot facing  
East & West Roads**

**(Good)**

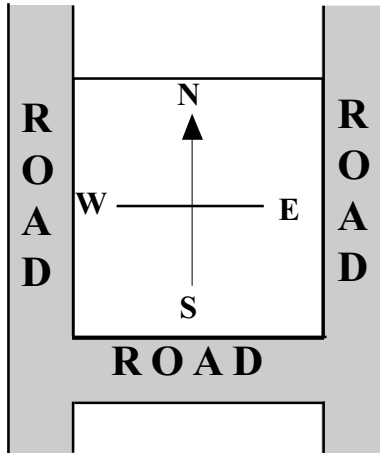


### Plot having roads on three sides

**Plot facing North, East & South Roads**

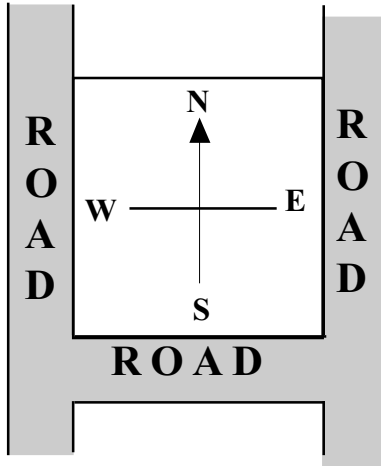


**Plot facing East, South & West Roads**

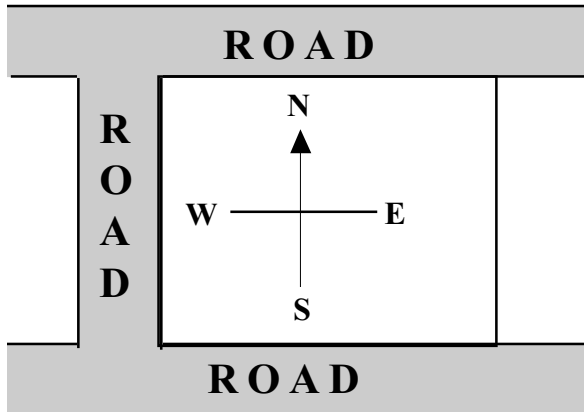


**(Plot facing three side roads are average plots)  
It can be improved by providing passage  
on fourth side.**

**Plot facing West, North  
& East Roads**

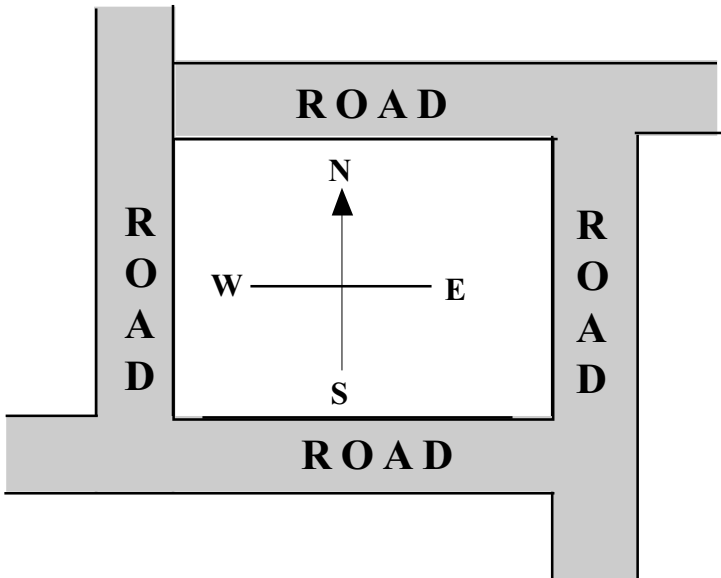
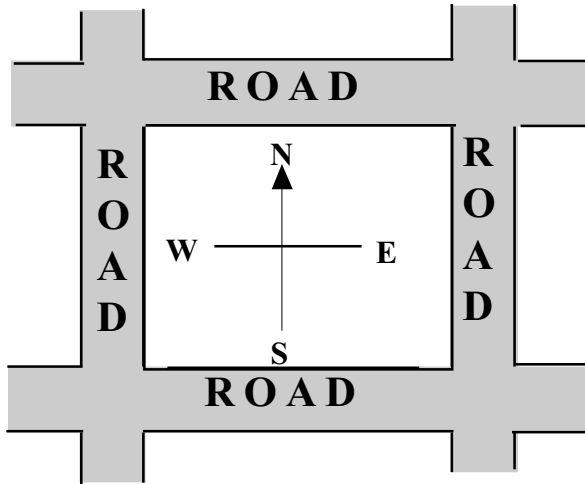


**Plot facing South, West  
& North Roads**



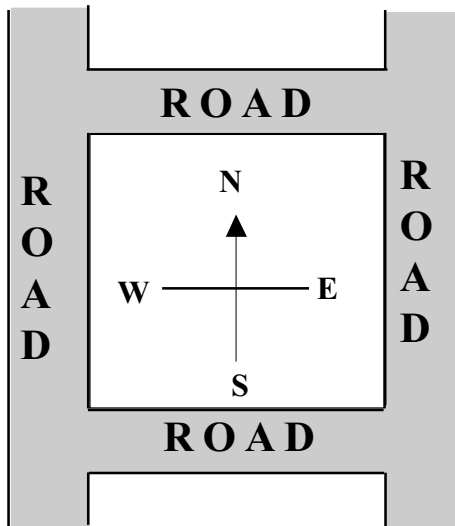
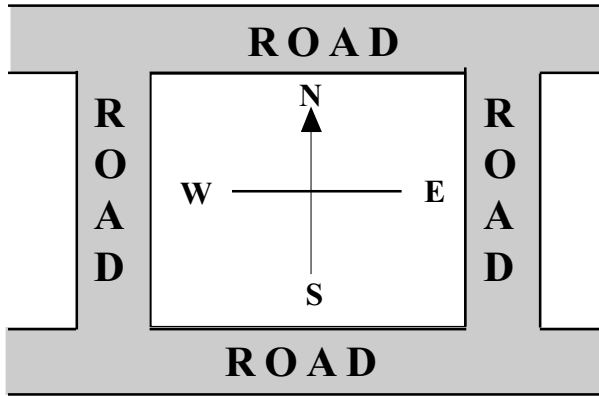
**(Plot facing three side roads are average plots)  
It can be improved by providing passage  
on fourth side.**

## Plot having roads on all sides



**(Plot facing roads on all sides is the best plot)**

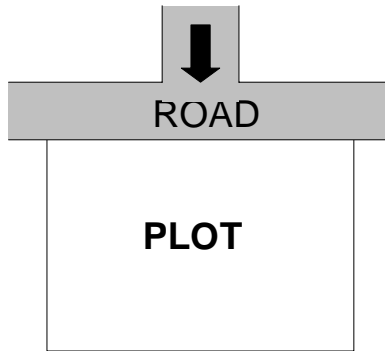
## Plot having roads on all sides



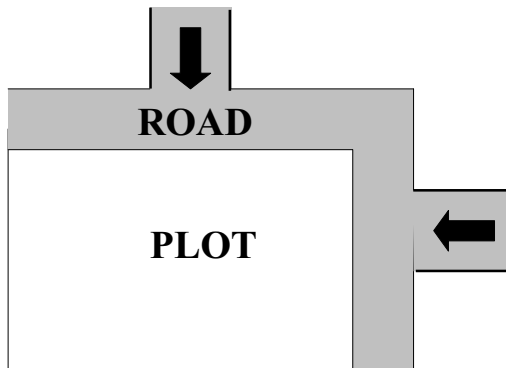
**( Plot facing roads on all sides is the best plot )**

## Plot having T- Junction

**Plot facing one side  
Road with T - Junction**



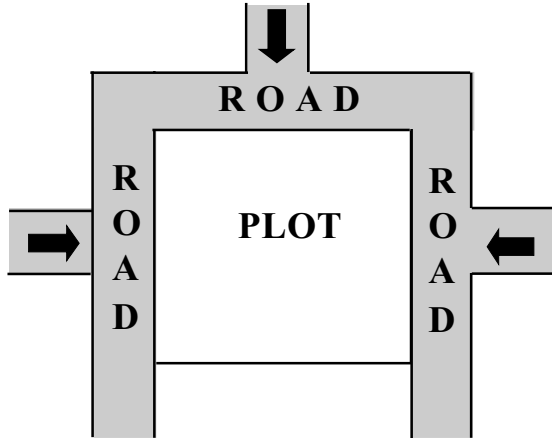
**Plot facing two side  
Roads with T - Junctions**



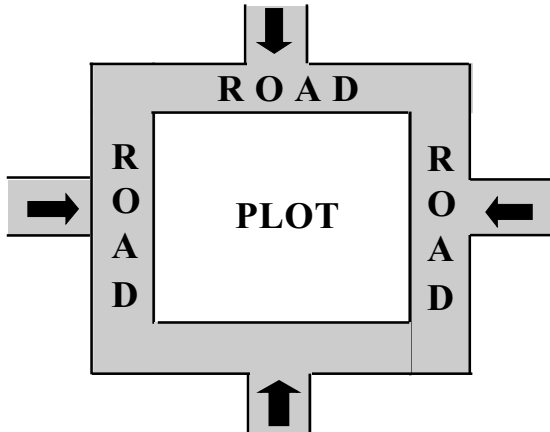
**(Plot facing road with T - Junction is weak)**

## Plot having T- Junction

**Plot facing three side  
Roads with T - Junctions**



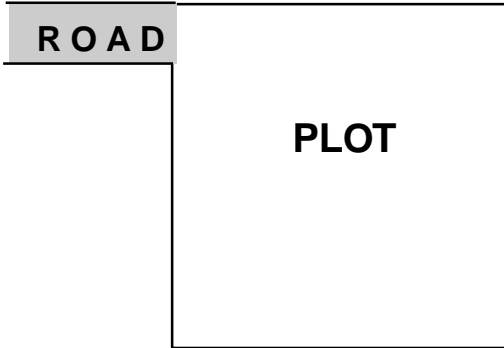
**Plot facing all side  
Roads with T - Junctions**



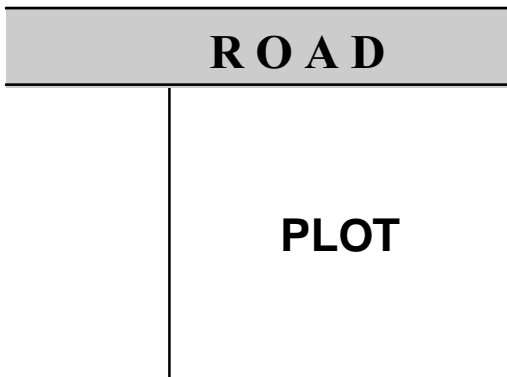
**(Plot facing road with T - Junction is weak)**

## Plot at the dead end of the road

**Plot at the end of the Road  
( Inauspicious)**

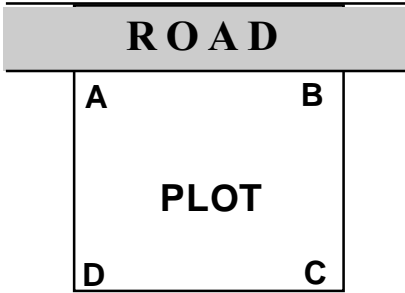


**By simply extending the  
Road upto the plot width as  
shown, the plot becomes aver-  
age.**

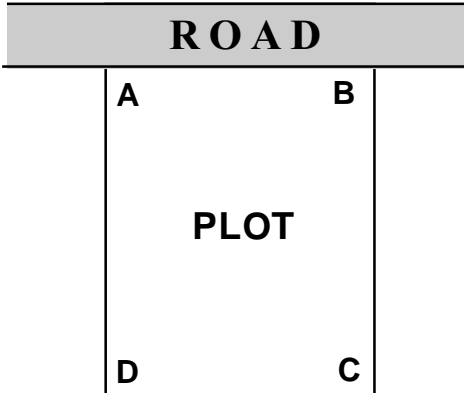


# SHAPE

## Regular Shape



**Square Shape**  
 $AB = BC = CD = DA$   
 $AC = BD$   
All Angles are  $90^\circ$   
**(Prosperity)**

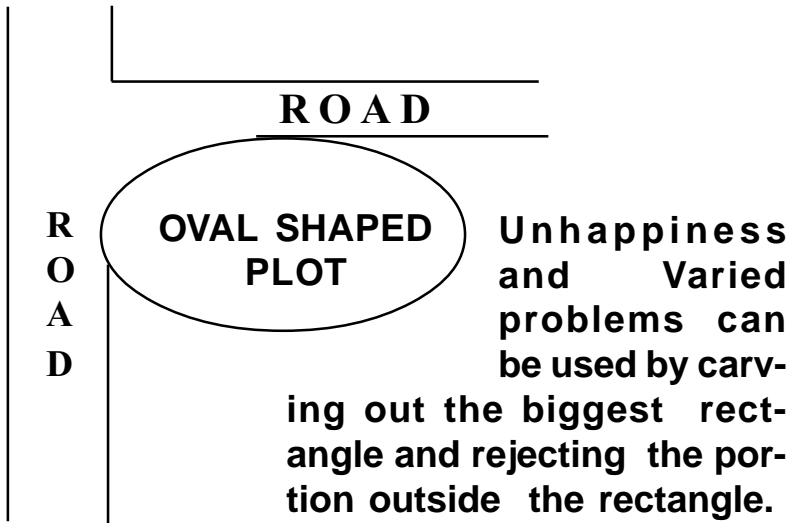
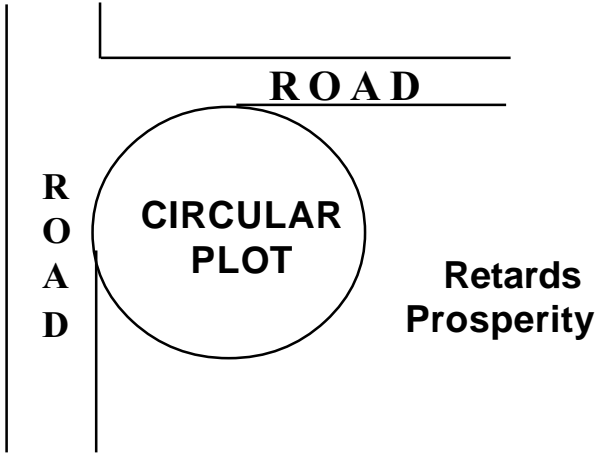


**Rectangular shape**  
 $AB = CD$  (Width)  
 $BC = DA$  (Depth)  
All Angles are  $90^\circ$   
 $AC = BD$   
**(Financial Growth)**

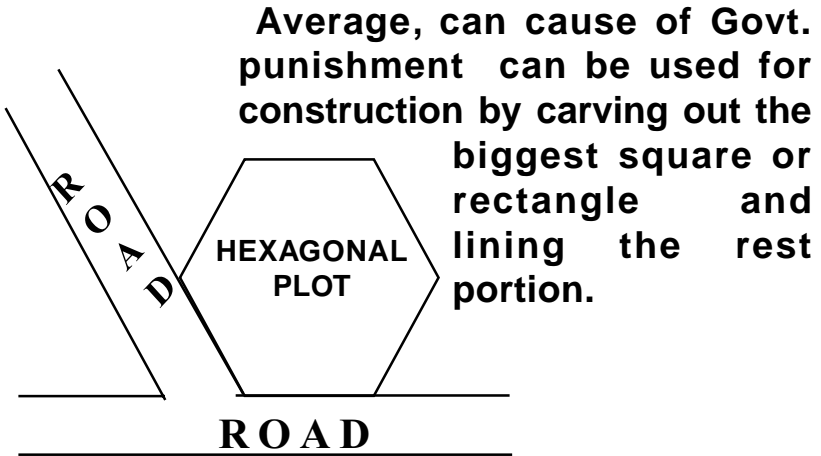
\* If depth is more than twice the width, plot becomes average.



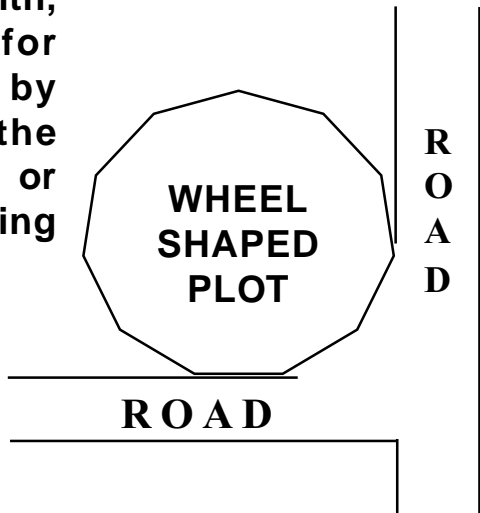
# SHAPE



# SHAPE

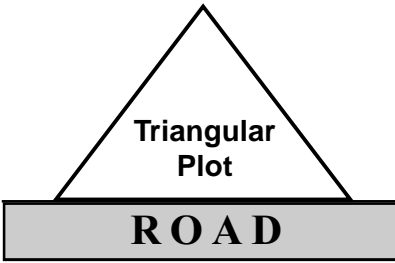


Loss of Wealth, can be used for construction by carving out the biggest square or rectangle & living the rest.



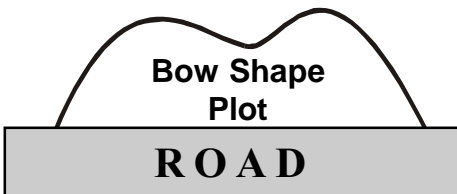
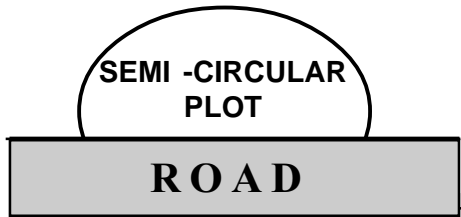
# SHAPE

## Irregular Shape



**Legal problem , Loss by Fire and Instability Govt. Harassment, Penalty etc., can be used by carving out maximum square or rectangle**

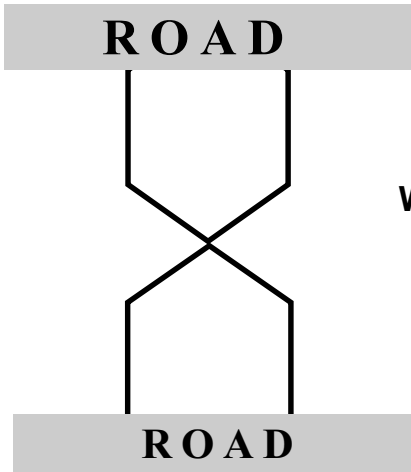
**Unhappiness Poverty should be rejected or carve the biggest rectangle rejecting the portion.**



**Various Troubles , Enemity , Fear should be rejected or carve the biggest rectangle rejecting the portion.**

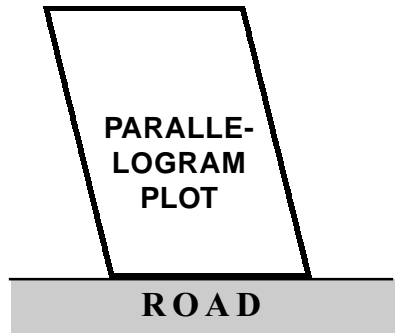
# SHAPE

## Reverse Cart Shaped Plot

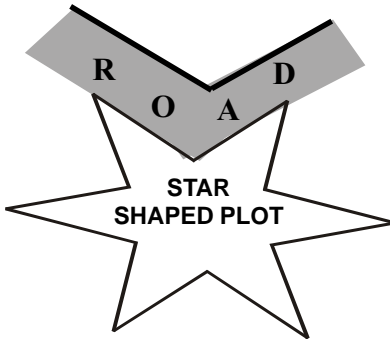


**Weak causing Loss  
Due to Theft ,**

**Inauspicious, Enemy  
causing Disputes, Quar-  
rels  
in Family , can be used  
for construction after  
carving out biggest  
square or rectangle  
leaving the rest.**

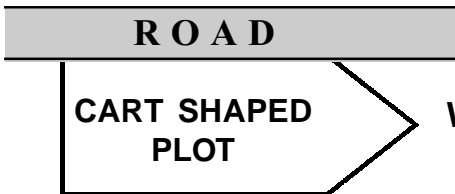
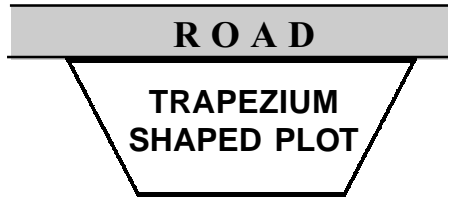


# SHAPE



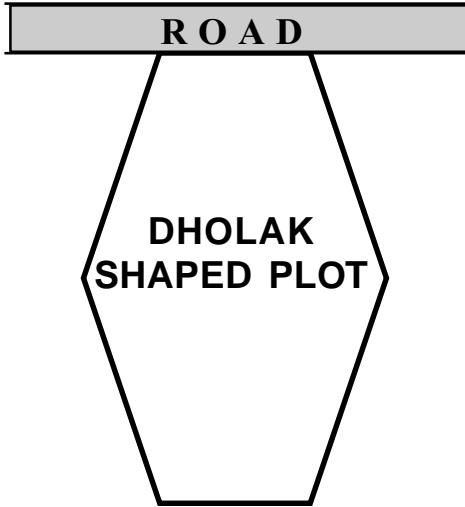
**Legal Problems,  
Confusion, Loss of  
Wealth.**

**Weak causing  
Unhappiness, Loss  
of Wealth, can be  
used after carving  
out rectangle  
leaving the  
balance.**

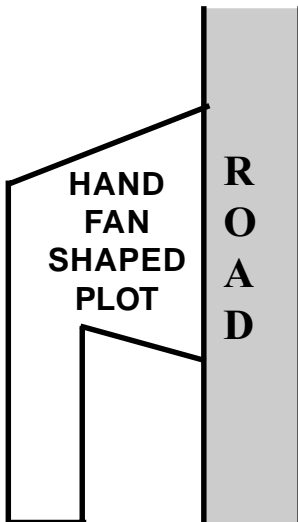


**Weak causing Illness  
& Poverty**

# SHAPE



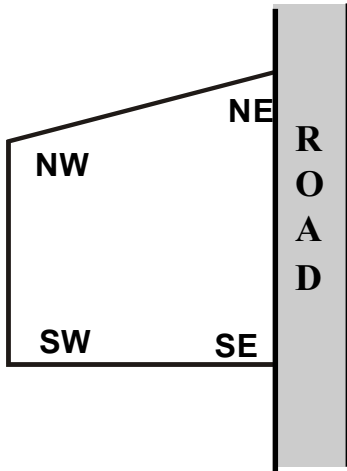
**Weak causing  
Death of Wife**



**Weak causing Loss of  
Cattle & Loss of  
Wealth**

## Extension of plot

### i) Extension at North - East Corner



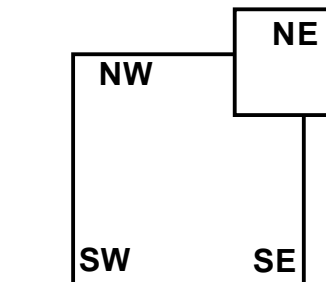
TOWARDS NORTH  
SIDE

(Prosperity)



TOWARDS EAST  
SIDE

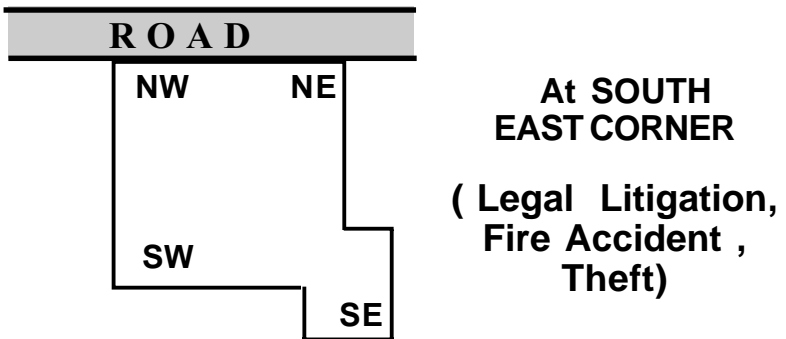
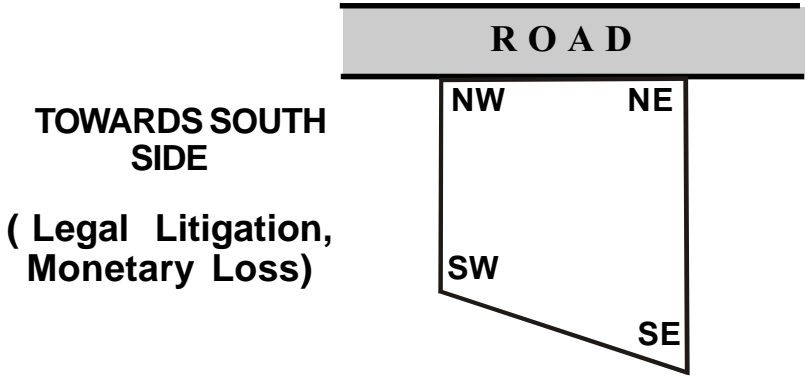
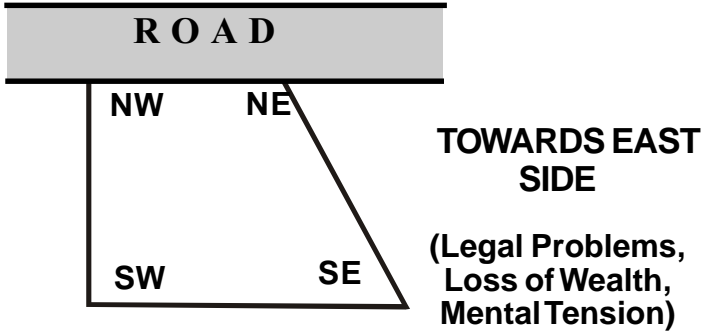
(Prosperity)



AT NORTH EAST  
CORNER

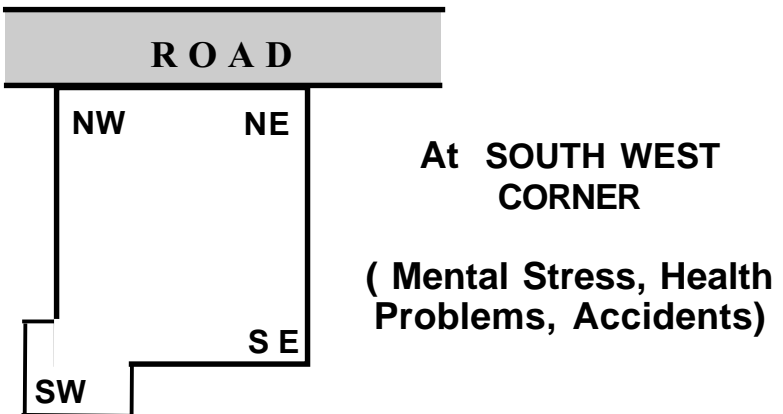
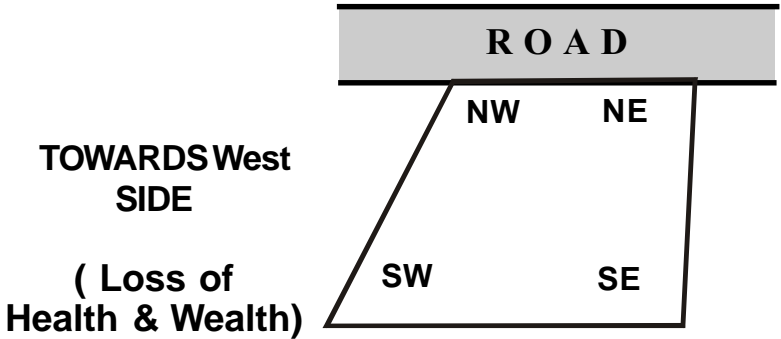
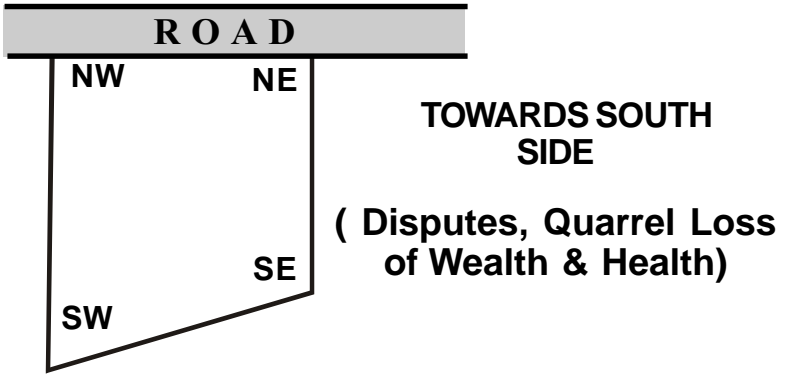
(Over all prosperity and  
good for health)

ii) Extension at South - East Corner

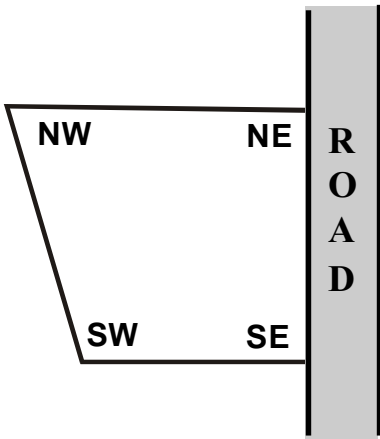




**iii) Extension at South - West Corner**



### iv) Extension at North - West Corner

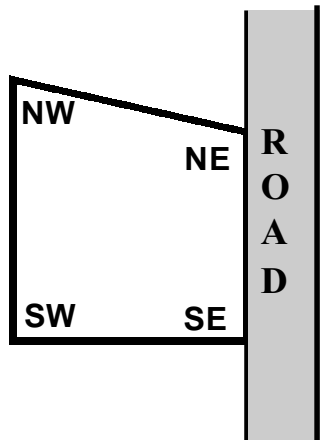


**TOWARDS WEST  
SIDE**

**( Financial Loss,  
Unwanted Expenses,  
Retards Progress)**

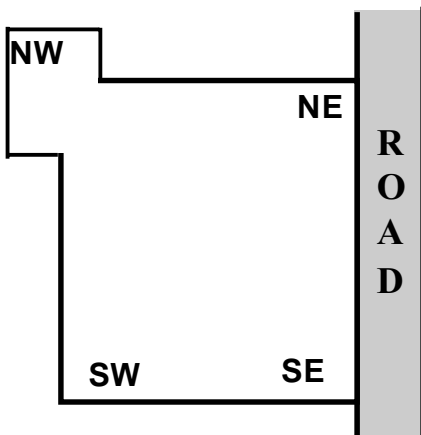
**TOWARDS NORTH  
SIDE of NORTH WEST**

**( Financial Loss,  
Retards Progress)**



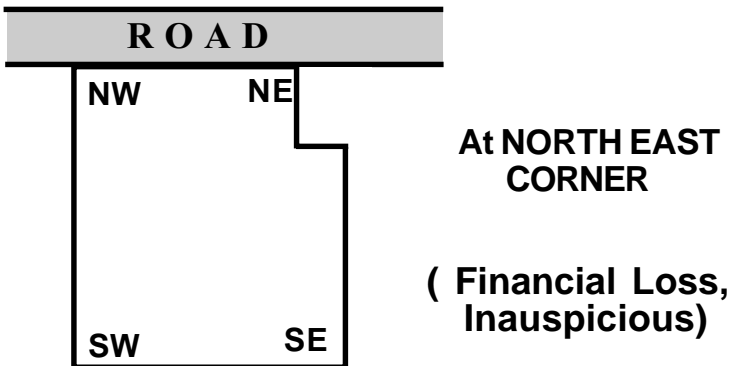
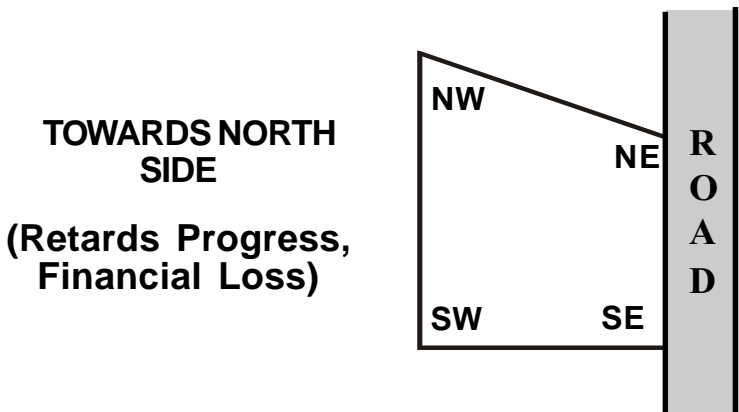
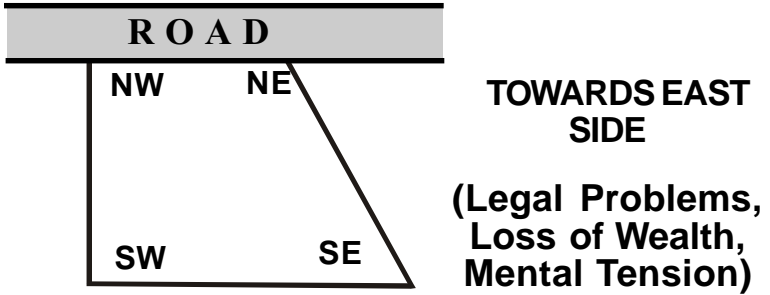
**At NORTH  
WEST CORNER**

**( Insatiability, Mental  
Tension,  
Poor Growth)**

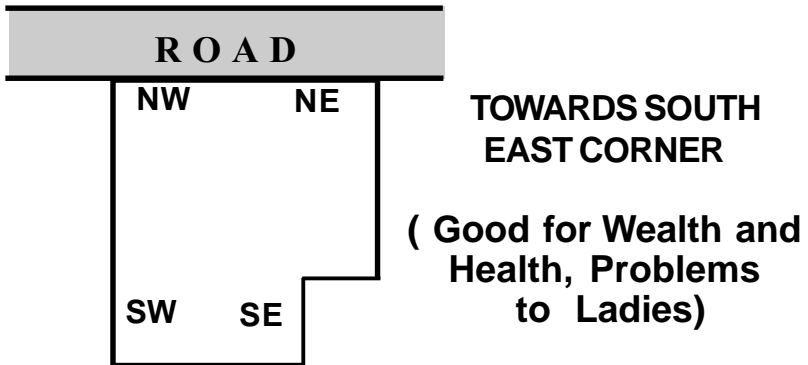
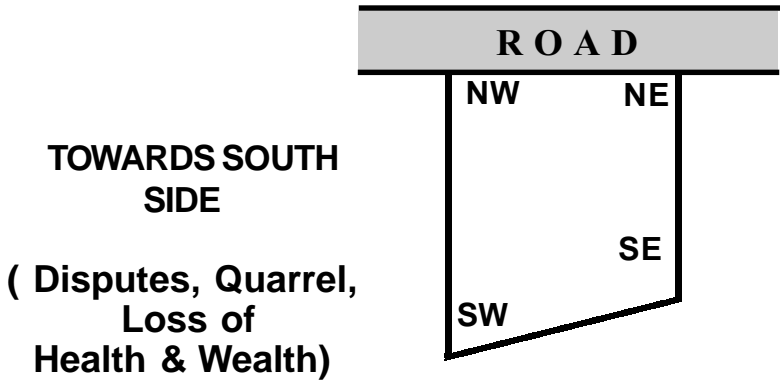
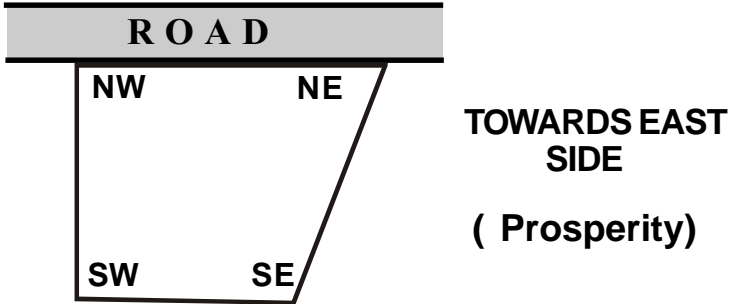


## Reduction of plot

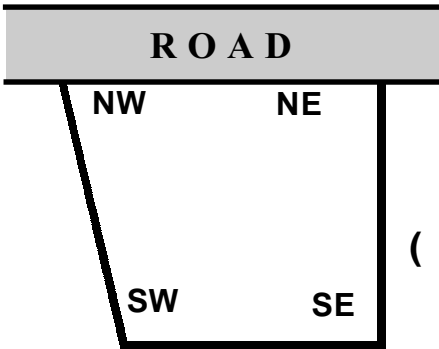
### i) Reduction at North - East Corner



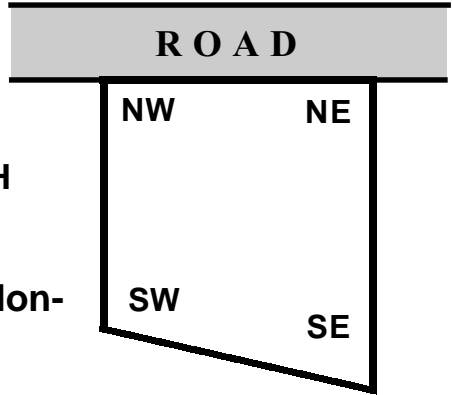
## ii) Reduction at South East Corner



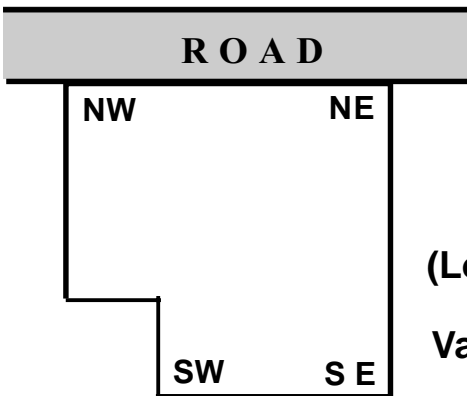
### iii) Reduction of South West Corner



**TOWARDS WEST  
SIDE**  
**( Unwanted Expenses,  
Retards Progress)**

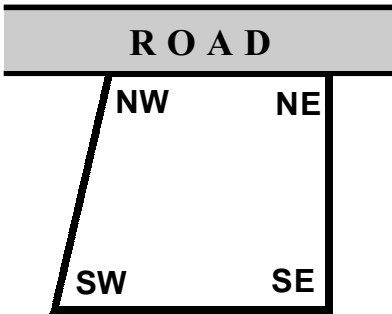


**TOWARDS SOUTH  
SIDE**  
**( Legal Problems, Mon-  
etary Loss)**



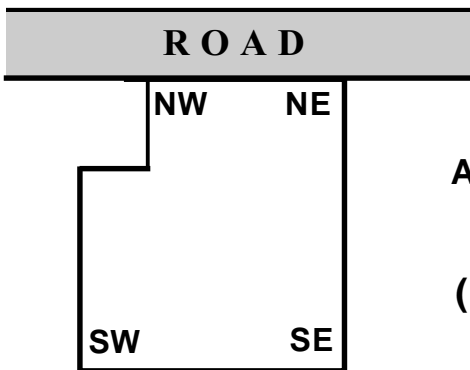
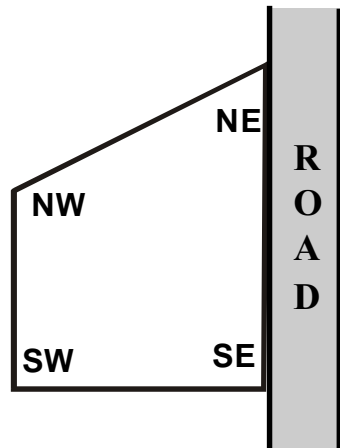
**At SOUTHWEST  
CORNER**  
**(Loss of Ambitions  
and  
Various Problems)**

### iv) Reduction of North West Corner



**TOWARDS WEST SIDE**  
**( Loss of Wealth and Health)**

**TOWARDS NORTH SIDE**  
**( Prosperity)**



**At NORTHWEST CORNER**  
**( Growth and Prosperity)**

\*\*\*\*\*

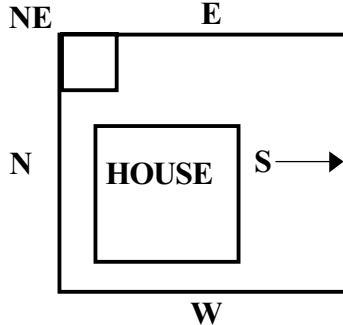
## 14. EFFECT OF THE CORNERS

---

Some space should be left out vacant on all the four sides of plot and, on the remaining part of the plot, a house, a factory or a business organization must be built. This guideline applies not only according to 'Vaastu Shastra' but also as per the rules of Municipalities and Land-limit pattas.

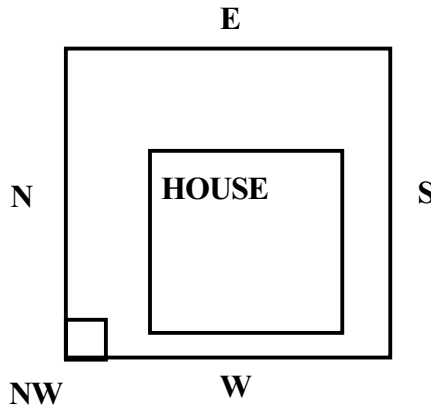
If the corners are closed, some unexpected calamities make the owner of the plot suffer, as explained hereunder :-

### (a) Covering the North - East corner :



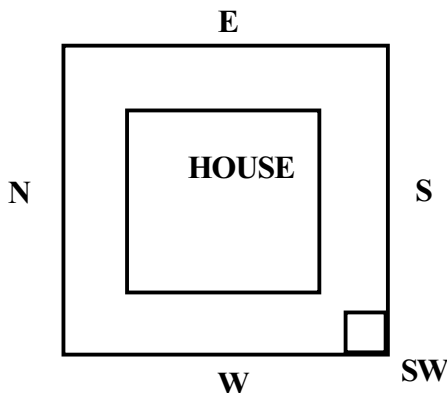
It is well known that the corner where East and North sides meet is called N.E. corner. The presiding deity of this corner is Ishan or Ishwara. He carries 'Ganga' on His head. If any weight is put on His head, 'Ganga' is arrested and water which is one of the vital elements doesn't flow down. Life comes to a standstill, when water is not available. So to avoid destruction no weight of any kind should be placed, under any circumstances, in the N.E. corner.

**(b) Covering the North - West corner :**



The presiding Deity of N.W. corner is 'Vayu' who is the Lord of winds. If this corner is closed, there will be no air without which no living being can exist. Hence, N.W. corner should not be closed. If there is some closed construction in the N.W. corner, the owner of the building, let it be house, factory or business complex faces mental problems slow pace of progress & becomes an insolvent. There are many cases of this type. So it is indispensable to demolish such a building that is constructed in the N.W. corner :

**(c) Covering the South-West corner :-**

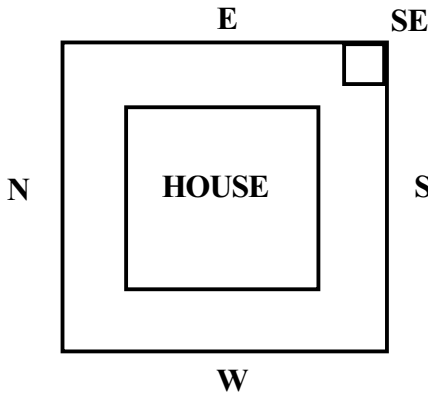




The Master of the S.W. corner is a demon names Nairutijan Naishan. To control this demon; heavy things or lumber should be dumped in the S.W. corner. When a house is built in the S.W. corner, building should be constructed on a higher level than that of ground.

When the plot is lower in this area or a well, pit or ground, under water tank exists in South-West people living on that plot have a tendency to meet with accidents, commit suicide, meet with death in any fatal accident or become handicapped. So, the S.W. corner in the house should always be, under any circumstances, loaded with heavy things.

**(d) Covering the South-East corner :**



The presiding Deity of the S.E. corner is Agni-the Fire God. If the S.E. corner is covered for any reason, the Fire God devours everything. That is to say, both the landlord as well as the landlady will meet with premature death. Their wealth & progeny will also perish. So one must be careful in leaving the S.E. corner open.

\*\*\*\*\*

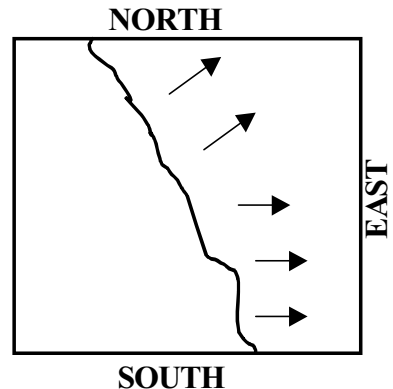
## 15. SLOPE OF LAND

According to the principle given in Vaastu Shastra the slope of the land of a plot has beneficial or baneful effect on the life, activities and achievements of the owner. Generally, the land having slope in the east is considered good for development and progress, slope in the north provides prosperity, slope in the west destroys knowledge and wealth, and slope in the south is supposed to bring diseases and death.

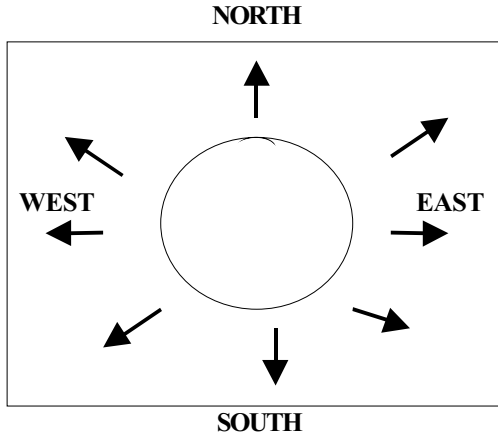
Land slope in the north brings monetary profit, slope in northeast (Eeshan) increases knowledge, slope in the east brings prosperity and comfort, slope in the Vayavya causes jealousy and fear from fire, slope in south causes death, slope in Nairitya causes monetary loss, slope in west causes loss of children, and slope in Aaganeya causes undesired migration, depression in the centre is much inauspicious and ominous.

While selecting a plot due precautions should be taken about the slope of the land. Land is divided into four categories on the basis of slope of the surface :-

**1. Land** elevated in South, West, Nairitya and Vayavya is called Gajprishtha (elephant - like surface). This provides increase in wealth and age.

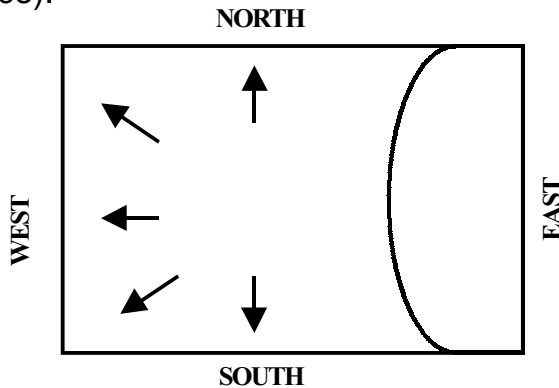


2. Land elevated in the middle and slope in four directions is called Koorma Prishtha (Tortoise like surface).



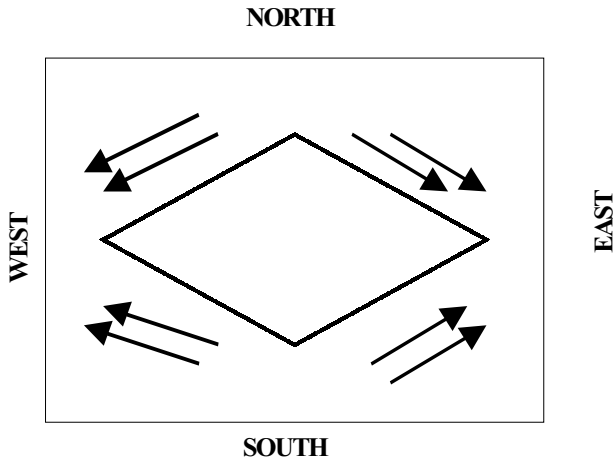
This provides prosperity, boosts courage and provides comfort.

3. Land elevated in east , north -east , southeast and depressed in west is called Daitya- Prishtha (Demon like surface).



Residents upon such will suffer loss of wealth, sons and cattle.

**4.** Longer from east to west, elevated in north-south and depressed in the centre is called Naag.



Prishtha (Snake like surface). Residing on such a land causes mental diseases, death and enmity. This is harmful for wife and children.

In Vastu Shastra beneficial and baneful effects of slope in different directions are described as follows :

**Effects of levels of site :**

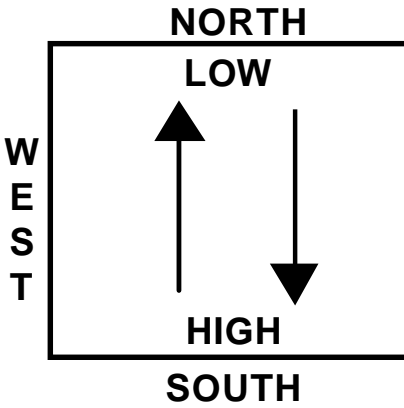
Directions	Low	High
East	Good Health, Wealth longevity, success,	Loss of spouse Progeny and other member of the family.

<b>Directions</b>	<b>Low</b>	<b>High</b>
South East east it creates	If lower than north fear of fire and enemies. It is also bad for women and male children	If higher than North East and North West it ensures finan- cial gains and and profit in business.
South	Restricts growth, causes diseases and financial problems	Good for health and wealth & Prosperity
South West	Will be the cause for bad habits, ill health death etc. of inmates.	Ensures all - round prosperity, popularity name and fame.
West	Causes ill health and loss of name and fame.	Ensures all- round prosperity.
North -West	If Lower than north east enmity, litiga- tions lower than South -West and South -East good.	If higher than north east it ensures success in Business & ensures fina- cial gain. If higher than South -West it is very Bad.

<b>Directions</b>	<b>Low</b>	<b>High</b>
North	Good for health wealth and Pros- perity in general	ill effects all round, has to face worst situation in every sphere.
North -East	Ensures good health -wealth, all round Prosperity and Popularity.	Will have to face innumer- able problems and the worst situation ini every sphere of life.

In brief it can be said that the plot we choose must be highest in (Nairitya) South-West corner and the lowest in (Eeshan) North-East corner. (Vayavya) North West corner must be higher than (Eeshan) North East corner and (Aagneya) South East corner must be higher than (Vayavya) North West corner. Residents of such a plot will enjoy a life of comfort, prosperity and progress.

# SLOPE



The land is higher on South and Lower towards North

(Overall Growth)

If land is lower on South and higher on North

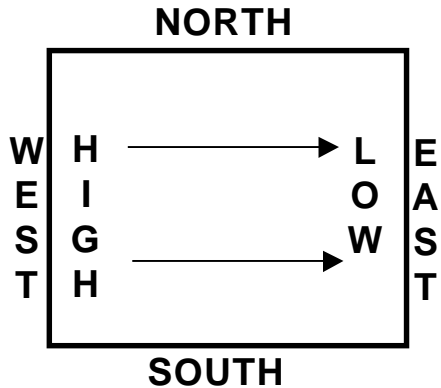
(Inauspicious)

Land is higher on West and lower in East.

(Prosperity)

Land higher on East and Lower in West.

(Financial Loss)

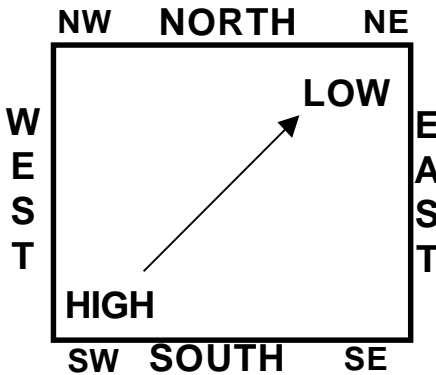


Land is higher on South West and lower North in East.

(Auspicious)

Land higher on North East and Lower in South West.

(Ill Health)



\*\*\*\*\*

## **16. PROPER SOIL SELECTION**

---

---

Vaastu places a great deal of importance on the proper quality of soil at the site for a house. An initial test of sorts is to dig two pits of the dimensions 2 feet by 2 feet by 2 feet. Care must be taken that the soil of the two pits is not mixed together. In one of these pits the soil should be put back. Once the pit is filled, the pits should be a residue of soil left over. If the dug-up soil exactly packs the pit or even worse, falls short, then the site is not regarded as being productive of prosperity.

The other pit is to be filled to the brim with water, in an ideal site, the water should take over an hour to be absorbed by the soil. If it takes less time than that, the site is regarded as a potential drain on resources. Large cracks left behind in the pit after the water drains away is a warning of extensive, construction expenses. A couple small cracks is not a matter of concern; if there are more than seven cracks, watch out.

A quicker test of soil quality is to dig the pit, fill it with water, and walk away for a length of 100 paces at your normal gait. When you return, a good site will retain over half the water, an average site between one-half the water, and a poor site; less than one-fourth.

\*\*\*\*\*

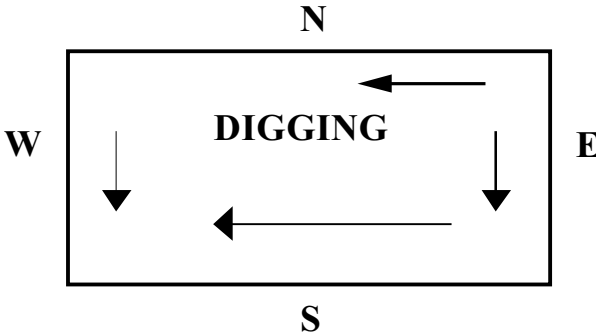


## 17. COMPOUND WALL OF THE BUILDING

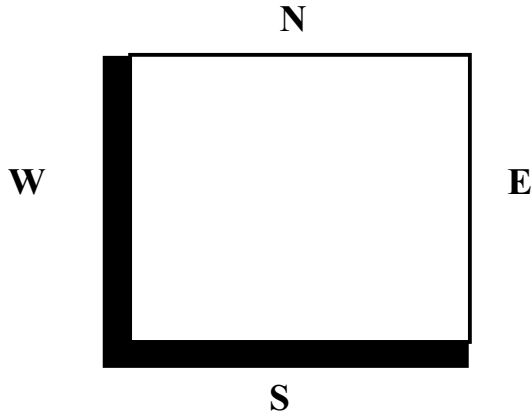
---

Before starting the construction of the house it is necessary to build the compound wall first.

- \* First demarcate the boundary of the plot. If it has an extended SE or SW corner the corner should make  $90^{\circ}$  by adjusting the extending portion.
- \* While digging the compound wall start from NE towards SW. Dig atleast 3 feet to 4 feet.



- \* The construction of the compound wall should start from SW towards SE and SW towards NW. NE should be finished in last.
- \* The thickness of wall on Southern & Western side should be thicker than Eastern or Northern side.



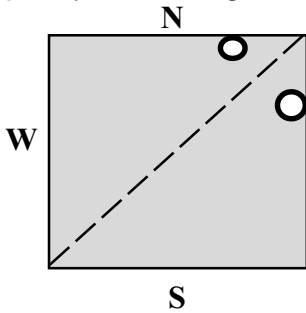
- \* There should not be any cracks in compound wall particularly in southern or western side.
- \* The angle at S/W of compound wall must be 90°.
- \* The height of the wall should be lower in North and East or N & E wall can raise upto 3' or 4' & then grill can be fix above to keep NE Wall lighter than S & West walls.

\*\*\*\*\*

## 18. LOCATION OF THE WELL /BORING

For wells, boring and underground water storage tanks following rules should be observed.

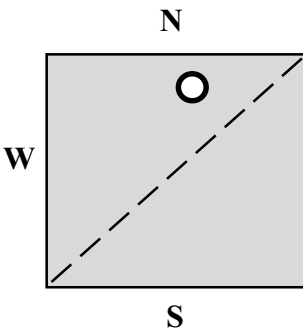
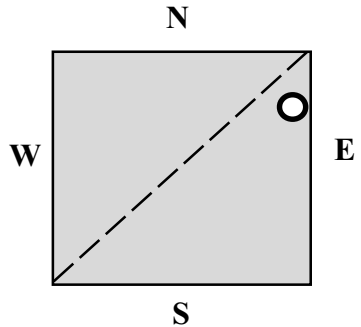
**1.)** The best place for digging the well is the north-east corner of the plot. This leads to increase in wealth, prosperity knowledge and increase in family.



**2.)** While digging the well, from the north-east corner to the south-west corner axis should be drawn. Care should be taken that the well does not intersect the axis. The well should be dug

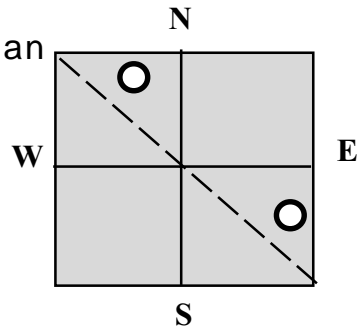
to the right or to the left of the axis.

**3.)** If the well is dug to the east side of the north-east corner it is most beneficial. There is an increase in wealth as well as prosperity.

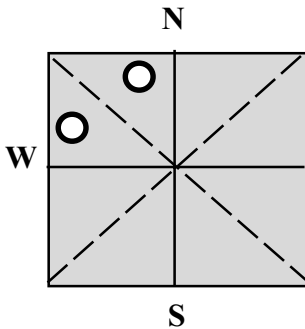


**4.)** However, if the well is dug to the north side of the north-east corner, there is an increase in wealth but reputation increases up to some extent.

**5.)** The well should be in the north-east corner less than half way to the east and the north sides. It should not be towards the south-east or the north-west corner. It should not be at the places as shown in the figure.

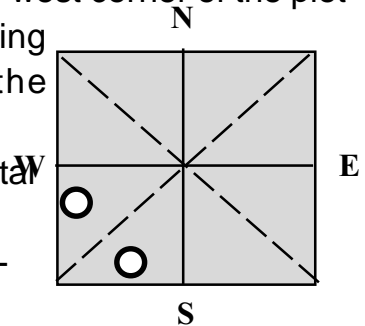


**6.)** A well in the east direction leads to prosperity, in the north leads to increase in wealth, in the west one has to face many difficulties and hardships. In the south, it leads to untimely deaths, deformities, frequent accidents, attempted suicide and bad ways.



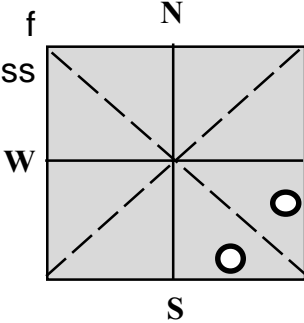
**7.)** If the well in the plot is in the north-west corner it leads to unnecessary enmity and fear from theft. The balance of life is lost.

**8.)** To have a well in the south-west corner of the plot is the worst. It has the following effects. The head of the family has an untimely death. Violence increases. There is total failure in every job undertaken, loss of wealth, suicide, clashes in the family lead to the breaking point.



**9.)** A well in the south-east corner has the following effects. Danger to children. Fire and water are two opposite elements. When they come together, life is full

of  
loss



clashes and troubles. There is of wealth & the clashes at home reaches the breaking point. Women suffer more losses compared to men.

**10.)** If there is a well at the centre of the plot or building, there is total destruction of the family. Nobody can stay in such places for a long time and life becomes unstable.

**11.)** All the above rules are applicable not only to residential buildings but also to business bldg., hospitals, temples etc.

**12.)** The well should be dug only after the worships of the land. Before digging the well, the place should be clearly demarcated. If the well is dug when the stars are favourable, the water is easily obtained at a low level and even the taste of the water is good.

## Effect of Bore well /Under-Ground Water Tank

Well Direction	Effects
North - East	All Kind of Happiness and prosperity.
East	Prosperity & Wealth Gain.
South -East	Loss of Wealth and Name & Fame of Owner Vanishes and Children in Problem.
South	Mental Sickness, Loss of Wife.
South -West	Death of head of the Family, Accident, Suicide.
West	Acquisition of wealth, develops a liking for spiritual Science & Worries Increased about the Health
North -West	Unnecessary Enmity, Theft Progeny effected, Mental Tension & Loss of Wealth.
North	Acquisition of Wealth, Happiness & Prosperity.
Centre	Bankruptcy.

\*\*\*\*\*

## **19. OVER - HEAD TANK**

---

---

- 1.)** The Overhead Tank should never be in the centre (Brahma Sthal). If so, life becomes helpless and one does not feel like living there. If the Overhead Tank from Brahma Sthal is removed and put in a proper place, one can achieve astonishing results.
  
- 2.)** As far as possible drinking water and cooking water-tank should not be of plastic. If so, it must be of black or blue colour, because it will absorb maximum sunrays. A white water-tank will reflect the sunrays and hence less beneficial. If possible there should be a separate water-tank for use in toilets and for other purposes.
  
- 3.)** If the water tank is on the West side leaving the SouthWest corner, it is O.K. West is Varun Devta's direction and he is the rain God. The Overhead Tank on floor level in this direction is permitted.
  
- 4.)** Overhead Tank should never be in the North-East. It will cause financial losses and accidents.
  
- 5.)** Water tank should be in the North-West, West or South-West. The Overhead Tank should be mounted on 4 legs of minimum 2' to 3'. If it rests on the terrace floor level, the direct weight of the Overhead Tank with water will create tensions on the residents.
  
- 6.)** The sunrays will fall first on the Overhead Tank it being the highest part of the house and they will be absorbed in water. Under no circumstances, the Overhead Tank in the South West should leak.

## 20. OBSTACLES IN FRONT OF ENTRANCE

---

---

**A) Dwarvedh** - The obstacles for air and light in front of the main entrance or the compound wall is known as dwarvedh. The meaning is that there should not be any obstacle in front of the main entrance. If there is any obstacle like electric pole, telephone pole, tree, water tank etc. it is known as Dwarvedh.

If there is an obstacle at a distance of twice the height of the building it is not considered as Dwarvedh, For example if the height of a building is 25 feet and if an obstacle is present at a distance of 50 feet from the main entrance of the building it is not considered as Dwarvedh. However, if it is at a distance of 45 feet it is considered as Dwarvedh, bad effects are definitely observed if there is Dwarvedh to a building.

**1) Swarvedh (Sound obstacle)** - There should not be any creaking sound when the door is opened or closed. Inauspicious happenings are expected to happen. This is known as Swarvedh. Oil the hinges so that craking sound will not appear.

**2) Kupvedh** - There should not be any septic tank, underground storage tank, boring, underground drainage canals etc. in front of the main entrance. This leads to loss of wealth and it is known as Kupvedh.

**3) Brahmavedh** - If there is an oil expeller, grinding mill or edge sharpener machine in front of the main entrance it is known as Bramhavedh. Life becomes



unstable and there are clashes in the family due to Bramhavedh. You can use different feng-Shui devices to mitigate the dwarvedh.

**4) Kilvedh** - If there is a peg to tie a goat, cow, buffalo or dog in front of the main entrance it is known as Kilvedh. This leads to obstacles in the progress.

**5) Stumbh Vedh** - There should not be any pole, electric pole, D.P. pole or telephone pole in front of the main entrance. It is known as stumbhbedh. This leads to difference of opinion among the family members or business partners. There are quarrels among them. This is harmful to progress.

**6) Vastuvedh** - There should not be store room, garage, out house, watchman cabin etc. in front of the main entrance. This is known as Vastuvedh which leads to loss of property.

**7)** The main entrance of a building should not be exactly at the middle of the length or the breadth of the house. It should be slightly to one side.

**8)** Water should not collect in front of the main entrance due to leakage in tap or any other reason. This is harmful to the children.

**9)** There should not be a heap of mud stones or bricks in front of the main entrance. This obstructs the progress.

**10)** The height of the compound gate should not exceed the compound wall columns on which gate is fixed. This obstructs the progress of the head of the family.

**11)** No other structure or its corner should face the main entrance of the building.

**12)** Outside the compound gate there should not be an incinerator in the East, the North-East or the North direction. Similarly there should not be any tank, pit or stagnant pool of water in South, the South-East or the South-West direction. These things are obstructions just outside the compound wall and are known as Margvedh. The head of the family faces many obstacles in his way.

**13)** There should not be a common entrance to two houses. Angry happenings take place.

**14)** The compound wall should not be higher than the building (It is not seen). It is written only for information. It is known as Bhawanvedh. This stops economic progress.

**15)** There should not be a delapidated abandoned building or remnants of an old building in front of the main entrance of any residential or commercial building. This results in daily loss and there is a chance of business getting closed.

**B) Chhaya Vedh** - If the shadow of a tree, temple, mountain, flag etc. falls on a building it is known as 'Chhayavedh'. There are five types of main Chhayavedhs.

**1) Temple Chhayavedh** - If the shadow of any temple falls on our building between 10 A.M.to 3 P.M. it is known as temple chhayavedh. This results in disturbance of peace. Business is badly affected and there is no progress. Delay in marriage of children and Progeny.

**2) Dhvaj Chhayavedh** - If the shadow of a flag or pillar or stup or samadhi or the flags on these structures falls on our structure it is known as Dhvaj Chhayavedh. This results in ill health.

**3) Parvat Chhaya Vedh** - If the shadow of a mountain or hill on the east side falls on our building it is called Parvat Chhaya Vedh. This results in obstacles in life, the name is spoiled. Therefore there should not be a mountain on the east side of the building.

**4) Vriksha Chhaya Vedh** - There should not be a large tree near the house. If the shadow of a tree falls on the building between 10 A.M. to 3 P.M. it is called as Vrikshachhaya Vedh. It obstructs progress.

**5) Bhawan Chhaya Kupvedh** - If the shadow of a building falls on the well or boring it is known as Bhawan Chhaya Kupvedh. This results loss of money.

\*\*\*\*\*

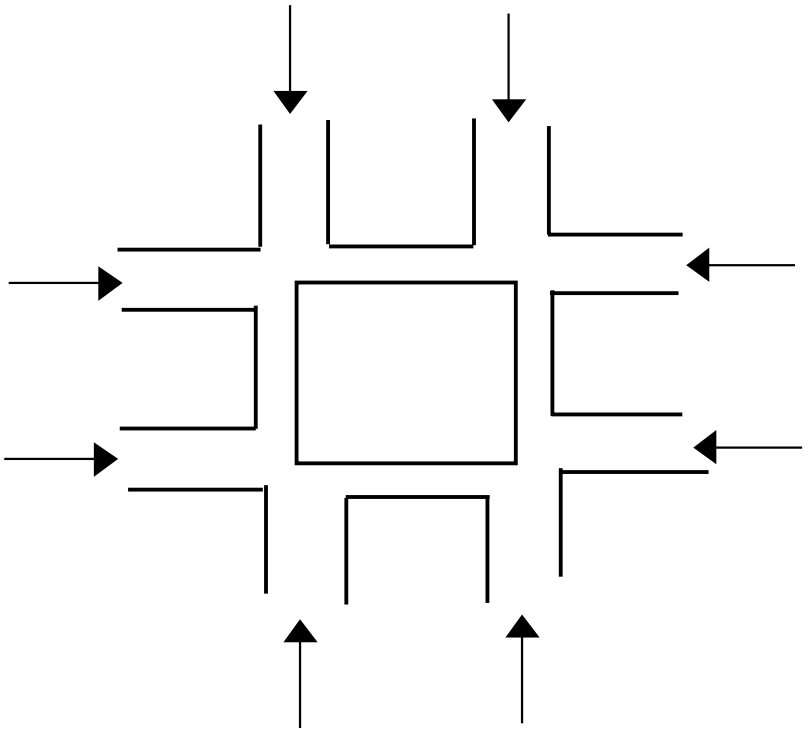
## 21.VEEDI SHOOLAS

---

---

### ***Veedi Shoolas :***

There are sites where roads or lanes run right into the face of site from different directions and these are known as Veedi (Road) Shoolas (Arrows). Some of them are good and others are bad. (Ref. Sketch Nos. 1 to 8)



# Veedi Shoolas

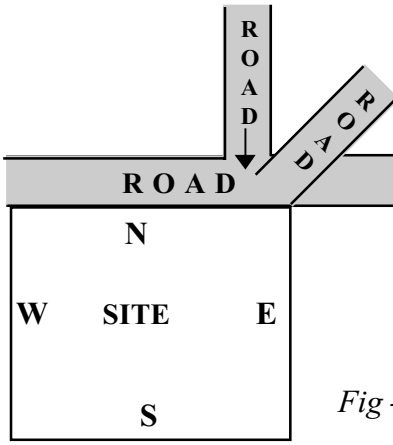


Fig -1

From North North -East  
 This is a Best Site gives  
 Name & Fame, Enhances  
 Avenues for Female,  
 Happiness, the Richest.

From East North -East  
 This is a Best Site  
 Improves Power and Au-  
 thority of Male host &  
 Happiness /Richness

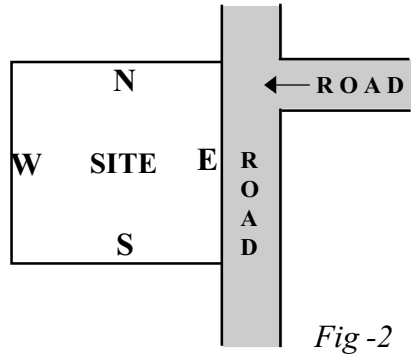


Fig -2

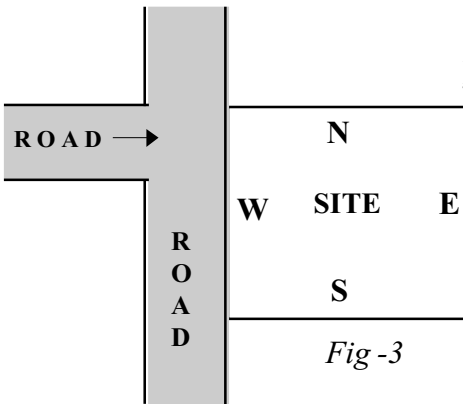
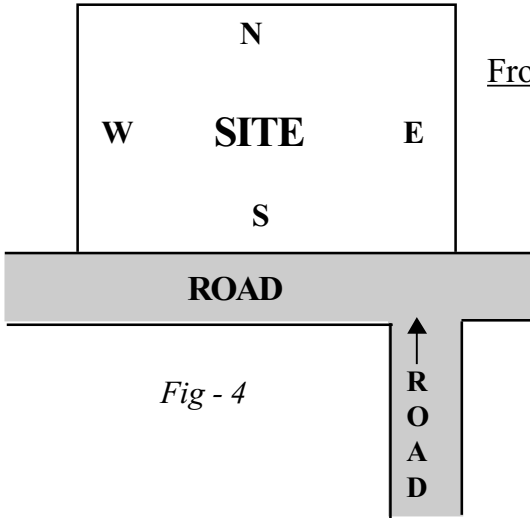


Fig -3

From West North - West  
 This is a Good Site  
 Enthrones Forward  
 to be Leader.

# Veedi Shoolas



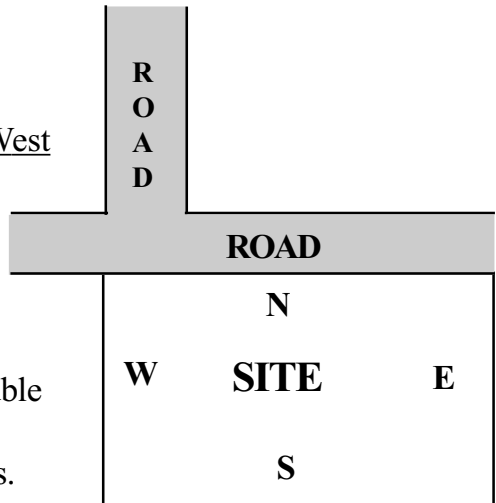
From South South -East

This is considered  
Good Veedi Shool  
Encourages the  
Host Towards  
Financial Better  
most.

*Fig - 4*

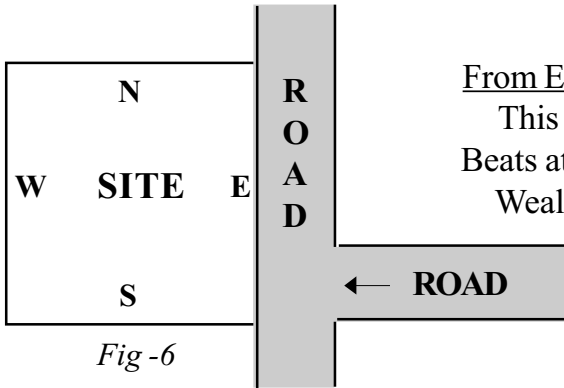
From North North -West

This is a Bad  
Veedi Shool  
Piercing Lance to  
the Pleasures of  
Female most.  
Causes Financial Trouble  
and Renders the  
Inhabitants Issueless.

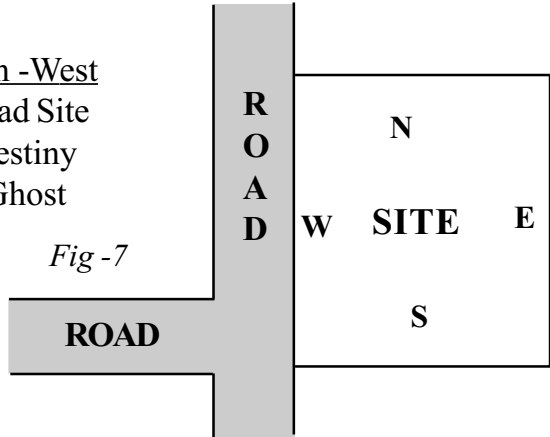


*Fig -5*

# Veedi Shoolas



From West South -West  
This is a Very Bad Site  
Punches the Destiny  
of Male as a Ghost



From South South -West  
This is a Very  
Bad Site  
Hit at the Wealth  
and Health of  
Female Most

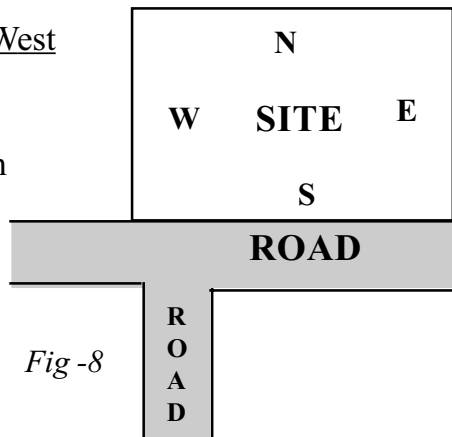




Fig -9



## **Example of Layout of plots having Vedi Shoolas :**

Since it is impossible to comment upon sites with different and innumerable permutations and combinations of road, direction, size and shape etc., let us examine one layout whereby a general idea about the merits and demerits of different sites can be gathered.

Plot No. 15 - Bad - East South-East - Veedi Shoola  
Plot No.19 - Good - East North-East - Veedi Shoola  
Plot No.04 -Not Bad - South South-East - Veedi Shoola  
Plot No.36 - Bad - North North -West - Veedi Shoola  
Plot No.28- V.Bad - West South -West - Veedi Shoola  
Plot No.32- Not bad - West North -West - Veedi Shoola

Plot No.27, 28, 29, 30, : These sites are good since the site extends towards North-East. Though Plot No. 28 is extending towards North -East it has Veedhi Shoola from South -West which is very bad.

Plot No.34, 8,11 : These sites are not good since North -East corner is rounded off. Rectification of these kind of plots is very difficult.

Plot No. 14, 15, 16,17 : These sites are bad since the South -West distnce is more than that from South - East to North -East to North -West. But the extension is towards South -West which is bad. These sites have to be reticied before use.

Plot No.18, 19, 20,31,32,33, : These sites are bad since the South -east to North-West distance is more than that from North -East to South -West. These sites should be corrected before the construction work starts.

Plot No.2, 3, 4, 5, 6, 22, 25, : These sites are good since they are rectangular or square in shape. But road is towards south.

Plot No. 7,10, 13, 26, 40, ; These sites have rounded off corners, towards North -west and South -East.

Plot No. 1, 21, 24 ; These sites are not good since South -West corner is rounded off, and North -East - South to West distance is less than that of South -East to North -West.

Plot N0. 12, 9 and 35 to 39 : These sites are good since they are either rectangular or square and the road is in the Northern side.

### **Overcoming the Problem of Veedhi Shoolas**

Example : The example shown below is about the site having the Veedi Shoola in the North, North West corner which is bad. To overcome this problem a portion in that particular corner ( the width of which should be equal to that of road, the Veedhi Shoola) has to be demarcated and sold to a third party as

vacant plot or along with a building. In such a case the site sold will be having Veedhi Shoola from the North which is good. As a result of this the main site gets rid of the problem. Similarly other cases with Veedhi Shoolas from different directions can be solved. But care should be taken with these kind of cases, so that when getting rid of evil effects of Veedhi Shoolas one is not left with a site having extensions to unfavourable directions.

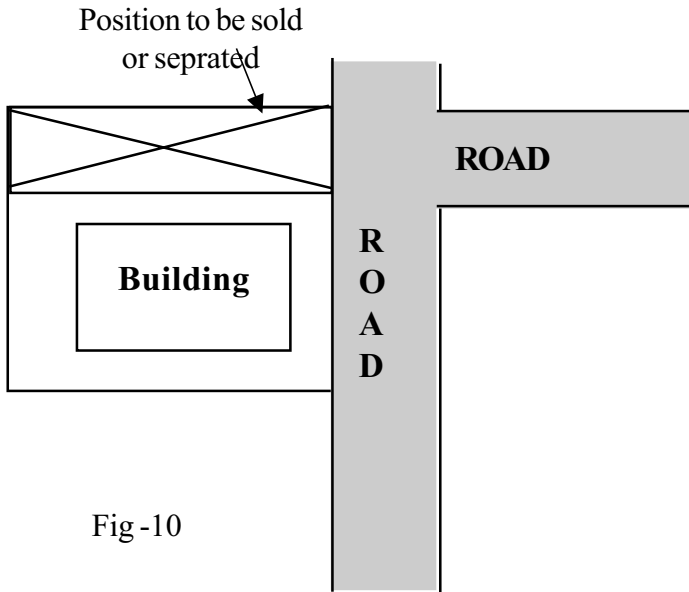
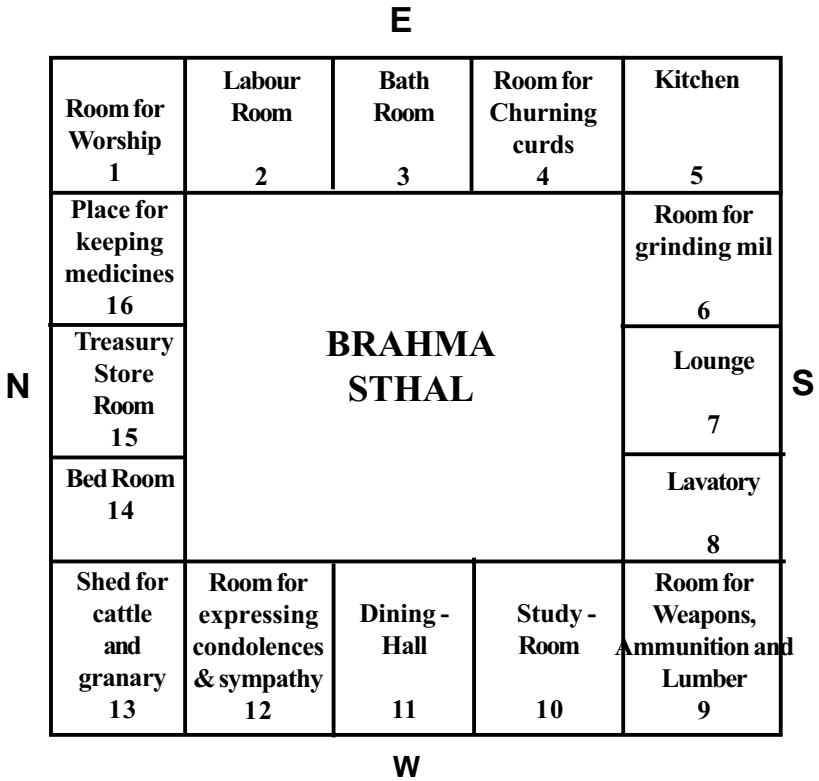


Fig -10

**The bad effect of Veedhi Shoola is eliminated and also no other bad effects from extensions to unfavourable directions.**

\*\*\*\*\*

## 22. VARIOUS PARTS OF A HOUSE



The Rishis of ancient period clearly clarified in the 'VAASTU SHASTRA' which things should be kept where and how to do a certain work. It has been shown in the above plan how a house should be arranged and decorated.

**(1) Room for Worship :** At the sun -rise the rays of the sun fall on the N.E. side of any place. So it was decided that the room for worship should be on the

N.E. If any type of building is raised on the N.E, the owner of the house will have mental worry and becomes dull. So, the N.E. corner should be kept separate only to install God's idol and worship it . It is also advised to plant a Basil plant (TULSI) and worship it regularly except sunday.

**(2) Labour Room :** In olden days adequate arrangement were made in the living house only for the delivery of pregnant ladies. But , now a days Health Science has developed by leaps and bounds and health centres have been opened. According to the prevailing conditions, the labour room used to be constructed on the East of the house. The only reason for this was that the sun rays which give health at dawn were falling on both the mother and her issue. So a temporary labour room was constructed on the East. Even now, it was proved to be correct, doubtless, as per the Geographical as well as health conditions.

Doctors, now a days, are constructing labour room on the East only, leaving a little space on N.E. in their Nursing Homes. It is in conformity with the rules laid down in the 'VAASTU SHASTRA'

**(3) Bath Room :** It is an established truth that water flow on the North, North-East and East sides. So our ancestors used to construct Bathroom on the East. Soon after taking bath in the morning , people used to pray to the Sun offering 'Arghya' (water offered chanting Mantras). Hence, even today, it is advised to construct bathroom on the East side only in the house or on the open place. This satisfies the rules given in the 'VAASTU SHASTRA'.

**(4) Room for Churning Curds :** Our ancestors used to churn curds with a churning implement and separate butter from it. They used to tie the churning rod to a pole with a rope and churn curds tying another rope to the churning rod. This was done on the East at South East corner, because East is near to South East. Influence of fire is seen much in the South East. The effect of Bacteria also is very much less here. Another reason for having the room for churning on the South East is that it is very near to the kitchen.

**(5) Kitchen :** The presiding deity of South-East is Agni, the God of fire. Therefore, the sages laid down the rule that kitchen should be on the South-East. According to Hygienic Science the sun-rays indirectly help leaf vegetables which contain the ingredients necessary for food. Proteins and nourishing qualities. The "Purusha Sukla" says that the people should cook food containing carbohydrates well in required proportions, offer it to the god of fire first and then eat. Whatever it may be, cooking food is a 'yagna'(sacrifice). So to avoid any danger, kitchen should be built on the South East side.

**(6) Place to Keep Oils and Ghee :** In olden days people used to have a grinding machine to squeeze oil in the South leaving the South East. By this, it was convenient for cooks to reach oil etc. easily. But now a days it is not necessary to have a grinding machine, as there are Mixes and grinding machines run by electric current. They may be put in the South.

**(7) Lounge :** This should be in the middle on the South side so that the members of a family may take rest after lunch. But sages did not recommend to sleep in lounge in nights.

**(8) W/C Toilet :** This is to be built on the South. Now a days, the owner of the house may build the toilet attached to his bathroom. It may be constructed on the West also, but not in the S.W/N.E. under any circumstances.

**(9) Room for Keeping Weapons and Heavy Lumber :** These things must be kept in the room built in the S.W. corner. Heavy things and lumber must be dumped on the S.W. because the more the load the better. If the staircase leading to upstairs is built on the S.W. good results may be expected.

**(10) Study Room :** In olden days it was considered good that the place on the West towards S.W. is the best one for studies. The reason is the planets mercury, Jupiter, the Moon and Venus influence the place as mentioned below.

**(1) Jupiter -** Accelerates desire to study and curiosity to learn.

**(2) Mercury -** Develops intelligence.

**(3) The Moon -** Lays strength on the nerves of the brain.

**(4) Venus -** Functions like a coordinator and makes the man efficient.

Therefore the study-room must be in the West and one should sit facing N.E., East or North. The "VAASTU SHASTRA" lays stress on the point that if one sits for studies as per the directions given above, one becomes quite an expert and enlightened.

**(11) Dining Hall :** For taking food, the central part on the West is a useful one. Whatever one eats it is digested very easily.

**(12) Room for Expressing Condolences and Sympathy :** For this purpose best place is the Western portion attached to the N.W. The reason for this is the influence of the planets i.e.. the Saturn, the Moon and Ketu.

In addition to mourning that is the most suitable place to take a quick decision. When time is short and an immediate decision is to be taken, if one ponders here over any problem, he gets the solution in no time.

**(13) Place to Keep Tame Animals, Cattle and Birds :** The N.W. of a plot is the best side to keep the above said living beings. Granary also must be on the same side. If the N. W. increases or decreases, it affects the health of cattle.

**(14) Bed - Room :** Ancient sages suggested that the place attached to the room which is towards the N.W. on the North is good to be used as a Bedroom. It is good to lie down on bed keeping one's head on the West side, because the sun rises in the East, the presiding deity of which is Indira, the Lord of devatas (Gods). After rising from bed in the morning, if one offers one's salutations, turning towards the East, it amounts to offering salutations to all the Gods.

It is also recommended that one may sleep on one's bed putting the head towards the South and look towards the North. The presiding deity is Kubera, the Lord of Wealth. So it goes without saying that one is worshipping Kubera by living on bed facing North.



If one sleeps putting the head on the East and looking towards the West, one offers salutations to Varuna, the presiding deity of the West. The salutations benefit very much one's philosophical thinking, belief and practice.

But, under any circumstances one should not sleep putting his head towards the North and looking towards the South, because the presiding deity of the South is Yama. Only the corpse of a person is laid on pyre, putting the head towards the North, facing the South.

If one sleeps, for any unknown reason, putting the head towards the North and facing the South, one will have nightmares and sleepless nights.

Today, Health Science reiterates that a man needs adequate sleep to keep himself fit and healthy. So one has to pay heed to the rules enumerated above.

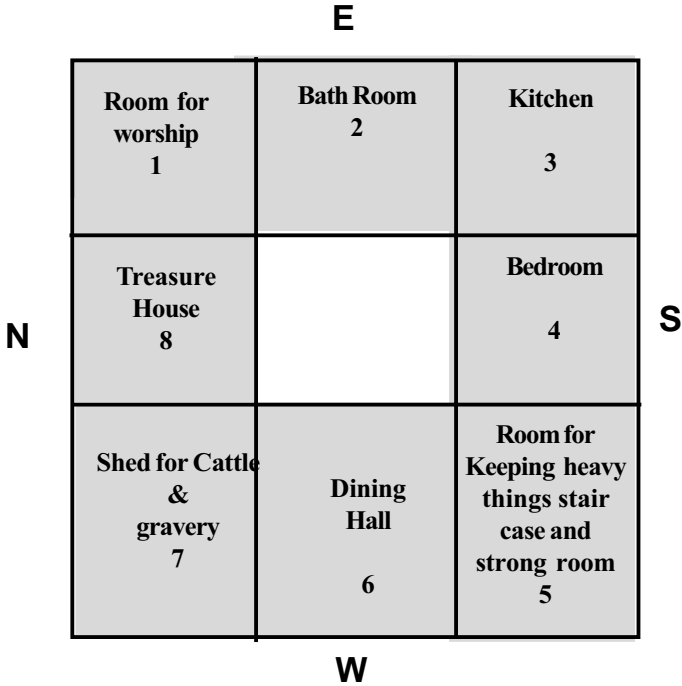
***(15) Place for Keeping Valuable Things :***

The best place for keeping valuable things and property is the central portion on the North. The presiding deity of the North is Kubera. So the North is the best side to keep safely most valuable things and property.

***(16) Place for Keeping Medicines :***

Our ancestors suggested that medicines should be kept in the N.E., because the sun - rays which have nourishing quality required for human health, fall at dawn, on the medicine and make them powerful to help human beings become hale and healthy. Today's Health - Science also agrees to this suggestion.

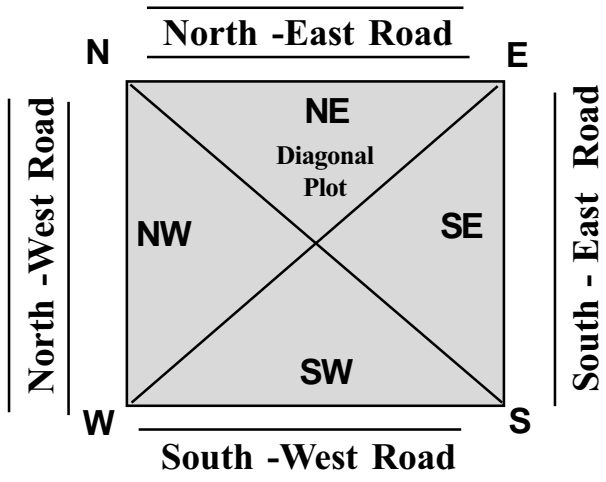
Keeping in view the economic condition of the people of today in our country, the 16 rooms shown in the plan given at the beginning of this Chapter have been condensed and adjusted into only 8 rooms as shown below so that a person might live in right rooms most comfortably , as he lives in house containing 16 rooms.



## 23. DIAGONAL PLOTS

**A.)** The plots in & which the major directions fall in the corners are known as diagonal plots. When the magnetic meridian instead of passing through the centre of the plot makes an angle of  $45^{\circ}$  with the main axis of the plot they are known as diagonal plots.

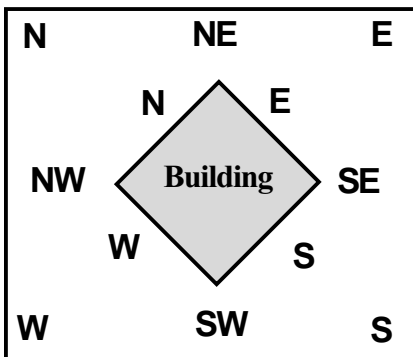
**B.)** The diagonal plots have the North-East, the North - West , the South -East and the South -West road sides. Out of these plots with road on the North -East side are very auspicious.



The North-West and the South -East road side plots are of medium level. The South -West road side plots are useful for certain profession, these plots should never be taken for residential purposes.

**C.)** The diagonal plots with roads on two, three or four roads give mixed results, however the South -West side should not be used as entrance.

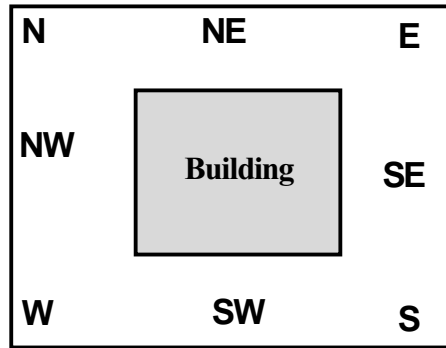
Facing of Road	Beneficial for
1) South- East Road	Residence, Hotels, Courts, business run by women, entertainment, factories etc
2) North -East Road	Residence, temple, school, Library, shop, factories etc.
3) .South -West Road	Hardware, type, permit room, accident hospitals, orthopedics etc.
4) North -West Road	Residence, Agricultural implements show room of vehicles, Garage etc.



**D.)** In the diagonal plots the construction should not be oblique or diagonal to the plot. As shown in the figure for getting the main direction the construction should not be

done. Every construction should be parallel to the direction of the plot and the adjacent roads.

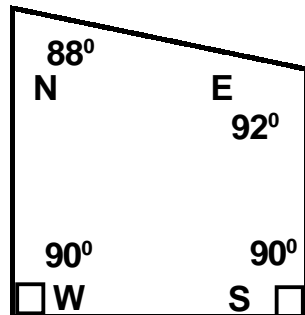
**E.)** If oblique construction is done the benefits of Vastushastra are obtained to a very small extent. Even if the plot is diagonal, construction should not be oblique. In the diagonal plot maximum open space should be left in the North -East direction. Then in the North-West direction at least 2 ft. more open space should be kept than that in the South -East and the South -West direction and the construction should be in the South-West part zone.

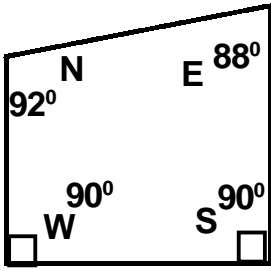


**F.)** The roads adjacent to the diagonal plots should not be haphazard or curved. At least in the compound wall of the diagonal plot no curve or oblique cut should be kept in any corner.

**G.)** The Western and the Southern angles of a diagonal plot should always be of  $90^{\circ}$ . It should not be more or less than  $90^{\circ}$ .

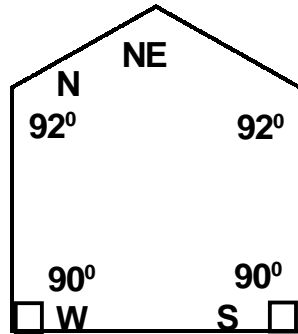
**H.)** If the Northern angle of a diagonal plot is of  $88^{\circ}$  and the Eastern angle of  $92^{\circ}$  it leads to increase in wealth but the fame is limited. In such cases it is essential that the Southern and the Western angles should be of  $90^{\circ}$ .



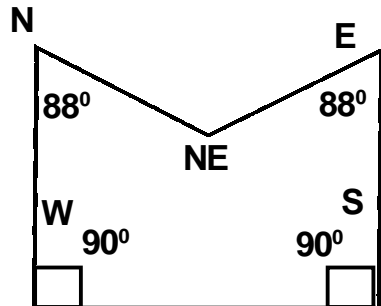


I.) The angle on the East side of a diagonal plot is of  $88^\circ$  and that on North is  $92^\circ$  one gets fame & publicity. However the money earned does not stay for a long time.

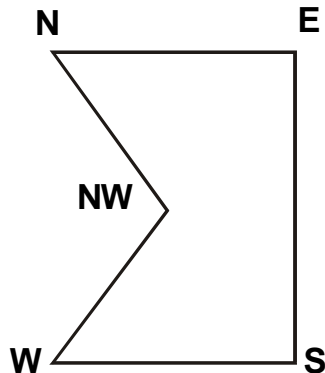
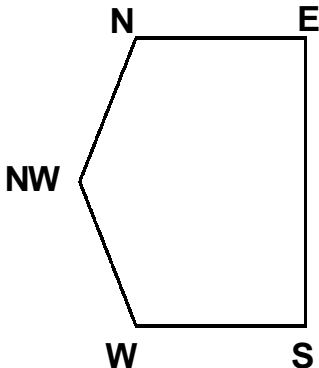
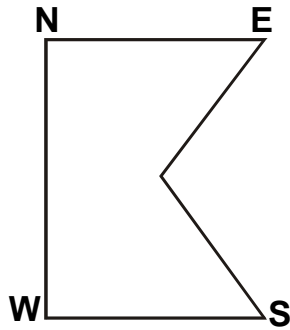
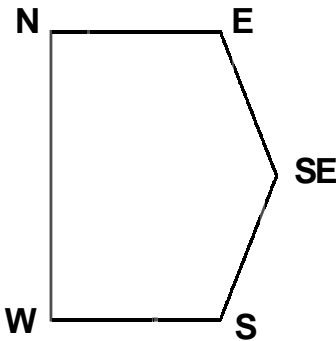
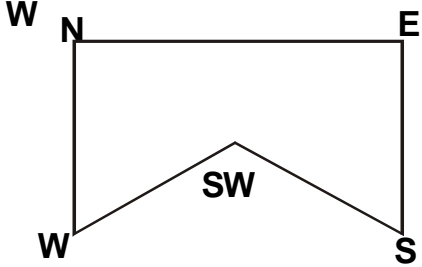
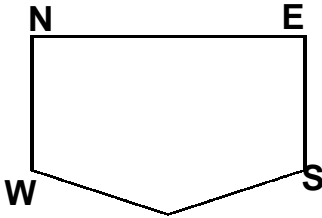
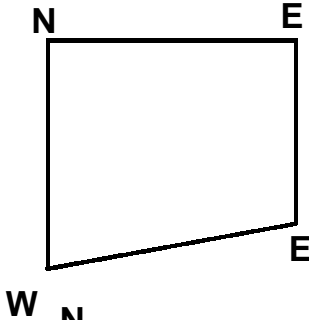
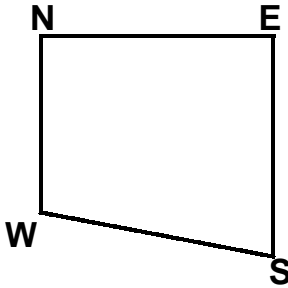
J.) If in a diagonal plot both the angles on the east and the North sides are of measure  $92^\circ$  it gives rise to a pentagonal plot. A person staying in such a plot faces instability. He follows and keeps on changing many professions. Wealth is earned but does not stay long. As far as possible such plots should not be purchased if at all it is purchased it is essential to make all angles of  $90^\circ$ .



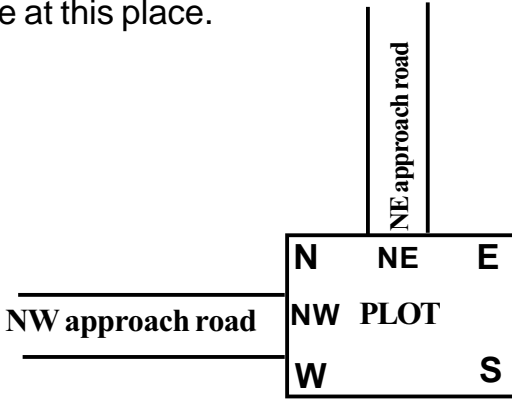
K.) If in a diagonal plot both the East and the North angles are measure  $88^\circ$  then in such a pentagonal plot the North-East direction is totally cut which leads to many calamities. By making it rectangular it can be used.



L.) The plots shown in the following figures should never be purchased. If purchased they should be made rectangular before use.

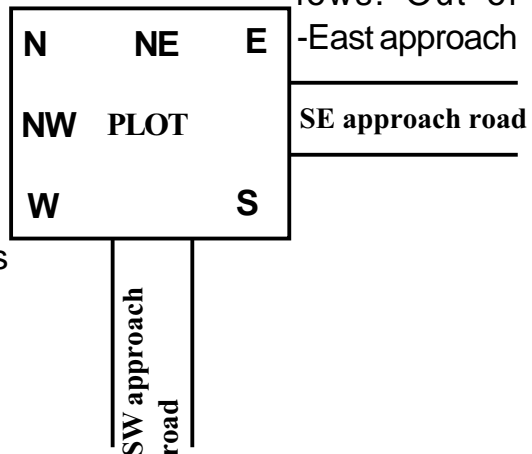


**M.)** For a diagonal plot the following approach roads are auspicious out of these the North -East approach road is very auspicious. We can have our compound gate at this place.



The North -West approach road is also auspicious. We can have our compound gate at this place also the North -West approach road gives medium level mixed benefits because of the half lying on the west side . In front of the road on the west side the gate of the compound wall should be constructed it should not be in the North direction.

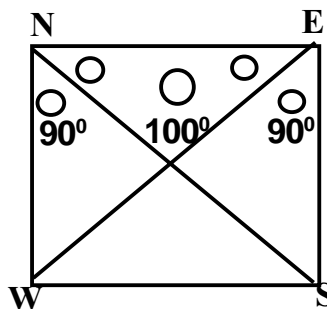
**N.)** For a diagonal plot in the auspicious approach roads are as follows. Out of them only the South -East approach road is beneficial to some extent for hotels, electric shops, Jewellers, business run by women etc. The benefits are average upto 50%.



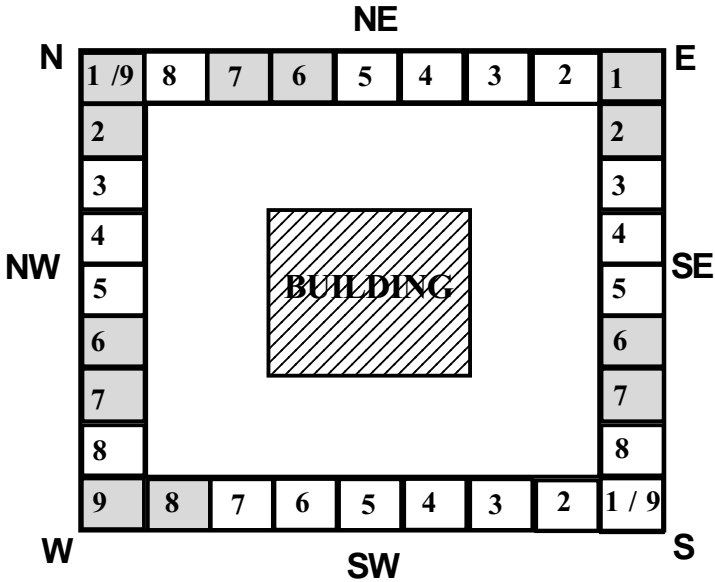


**O.)** While constructing the compound wall of diagonal plots only the North -East wall should be light, made of bricks. The South -West wall should be high, thick and made of stone. The South -East and North -West wall should be made of bricks having a downward slope from the South to the East and from the West to the North. These walls can be made sloping downward by giving descending steps. First of all the South -West then the South -East, then the North -West and at last the North -East wall should be built. The compound on North -East side should have the lowest height. Instead of a wall even a barbed wire fencing can serve the purpose. If the diagonal plot has a South -West road then the gate of the wall compound should be in the West. It should be small in size and closed . The gate should open towards the North.

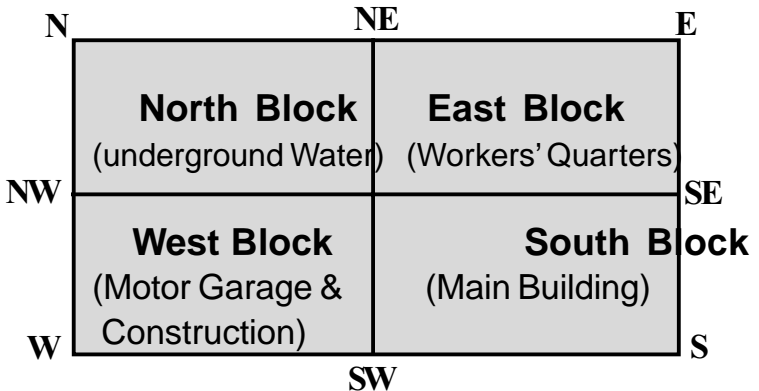
**P.)** In the diagonal plot the well or the boring should be in the North - East direction. Of course in front of the well there should not be any door of the compound wall or the building. If the well is in the East or the North it is beneficial. The well should be at the places shown in the figure. If it is at any other place it gives bad results. Wells at improper places should be filled up and closed after proper worship and request forgiveness.



**Q.)** The gate of the compound in diagonal plot should be at places as shown in the figure. It should not be in the South -West direction.



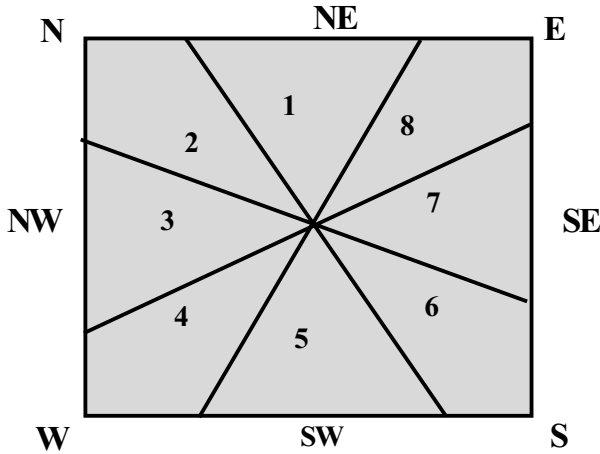
**R.) Division of a diagonal Plot**



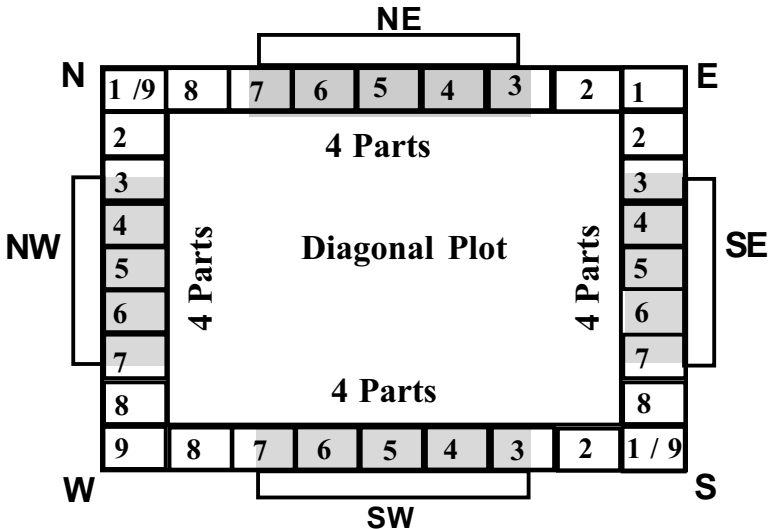
Taking into consideration the rectangular block of the diagonal plot the principal axis should be drawn at the centre of the plot taking into consideration the length and the breadth of the plot. Thereby dividing the plot

into four main blocks. The main building should be constructed in the South and the West blocks. The East and the North block should be kept open. Of course more open space should be left in the North -East side. Less open space should be left to the South-West side.

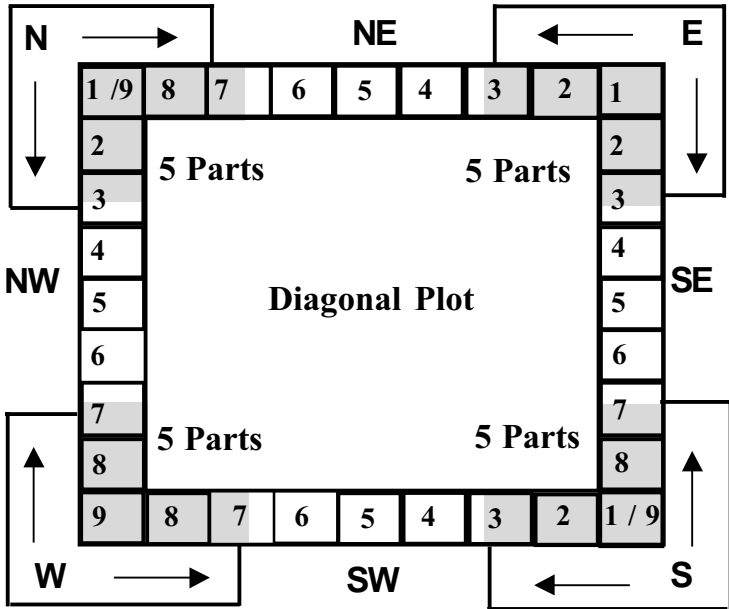
### Ashtachakra in the Diagonal Plot



In the Diagonal Plot Sub -directions has taken the place of Main Directions



In the diagonal Plot the Main directions has taken place of the sub -Direction



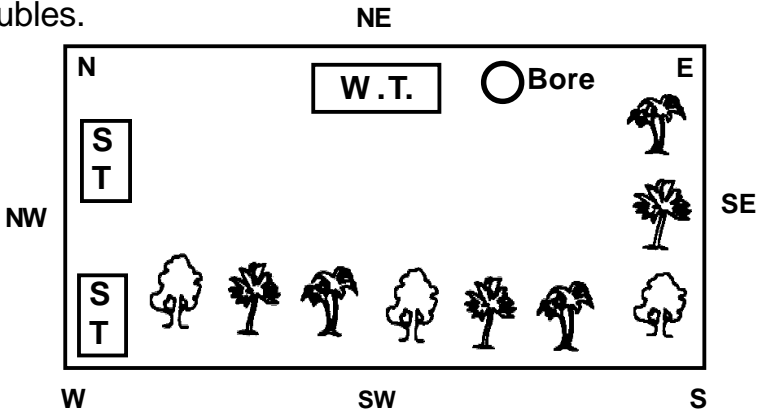
	<b>N</b>	<b>NE</b>	<b>E</b>	
	<b>North Safe</b>	<b>North -East Pooja Room</b>	<b>East Study Room</b>	
<b>NW</b>	<b>North West Dining Store</b>	<b>Brahma (Open)</b>	<b>South East Kitchen</b>	<b>SE</b>
	<b>West Children's Bed</b>	<b>South -West Store &amp; Staircase</b>	<b>South Master Bed</b>	
	<b>W</b>	<b>SW</b>	<b>S</b>	

**S.)** In a diagonal plot for the interior decoration of the main building the following chart should be used. Even if there is some fault in the construction of the building the loss is reduced from 100% to 50%. It is because as the magnetic meridian is not passing through the centre. The profits or losses of Vastushastra are of medium level. One can get a lot fame and money due to his Karma (Work). Even if the magnetic meridian is passing through the middle of the plot, if there are defects in the constructions, inspite of Karma (Work) proper fruits are not obtained. We can therefore call a diagonal plot profitable because the losses are also less.

**T.) Vaastu Ashtachakra for a diagonal Plot**

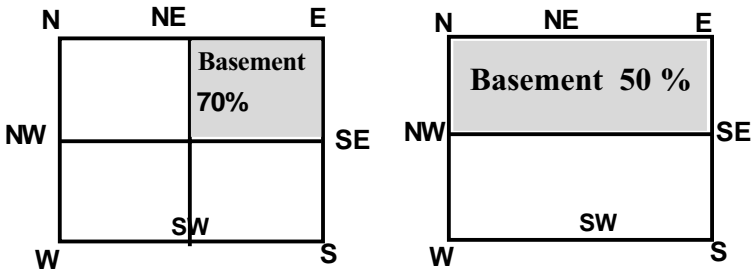
	<b>N</b>	<b>NE</b>	<b>E</b>	
	<b>Safe / Sitting Room</b>	<b>Pooja Ghar Sitting Room Drinking Water Study Room</b>	<b>Kitchen Children's Bed Bathroom Verandah Guest Room</b>	
<b>NW</b>	<b>Granary Children's Bed Washing Place Toilets Septic Tank</b>	<b>Brahma (Open Space)</b>	<b>Kitchen Electric Meter Store Room Children's Bed</b>	<b>SE</b>
	<b>Children's Bed Medita- tion Study room Stair- case head</b>	<b>Master Bed Stair case Store Room Lumber Room</b>	<b>Master Bed Store Room Entertain- ment Hall</b>	
	<b>W</b>	<b>SW</b>	<b>S</b>	

**U.)** In the diagonal plots for underground water storage tanks, septic tanks and platform should be as shown in the figure. However septic tank or water storage tank should not be situated in front of the compound gate otherwise it would lead to many troubles.

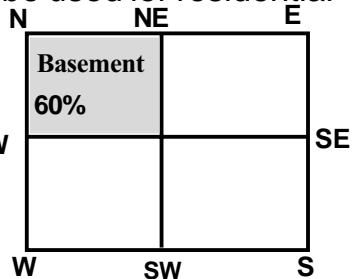


**V.) Basement in diagonal building**

For basement in the diagonal plot there is no harm if it is situated in half the place in the North- East



direction. However it should not be used for residential purpose. It can be used as godown only. Good or medium level benefits can be obtained as shown in the figure. However basement is never 100% good. It is better if there is no basement in a diagonal plot. However due to paucity of land if it is necessary it should be as shown in the figure.



\*\*\*\*\*

## 24. INTERNAL PLANNING OF A HOUSE

### **KITCHEN**

*(Control Health & Wealth of the Family)*

NW		N X		NE X
W X		Center X		E
SW X		S X		SE ✓

1. Kitchen should not be placed under or above pooja room Toilet or Bed Room. The kitchen should be in the southeast corner of the main building or flat .
2. The main kitchen platform should be in the east and the south-east corner.
3. Stove or gas burner should be in the south-east corner, a few inches away from the wall.
4. Adjacent to the kitchen platform, another 'L' shaped platform, near the south wall for keeping micro oven, mixer, grinder etc. will be very useful.
5. The washbasin (sink) of the platform should be in the north-east corner as far as possible. Pitcher of water and utensils for drinking water should be in the north-east or the north side.

- 6.** Essential commodities like boxes of grain, spices, pulses etc. should be in the south or the west direction.
- 7.** The entrance door of the kitchen should not be in any of the corners. Kitchen doors in the east, the north and the west are useful.
- 8.** The gas burner should not be in front of the main door of the kitchen.
- 9.** There should be one or two windows or air holes in the east and the west direction of the kitchen. An exhaust fan in this gap is useful.
- 10.** If there is a dining table in the kitchen, it should be in north west or the west side.
- 11.** Light weight articles can be kept in the east or the north.
- 12.** Mezzanine floor in the kitchen should be in the west or the south.
- 13.** While cooking, the face should be towards the east.
- 14.** The colour of the floor and the walls of the kitchen should be yellow, orange, rose, chocolate or red. However, it should not be black as far as possible.
- 15.** If a freeze is in the kitchen, it should be in the south-east, the south, the west or the north direction. It should not be in the north-east direction. If it is in the south-west direction it should be a feet away from the corner otherwise it always gets out of order.



**16.** If the kitchen is in the north-east direction mental tension increases and one may suffer great losses. If the kitchen is in the south-west direction, life at home becomes difficult because of clashes.

**17.** If the kitchen is in the north-west direction, the expenditure increases. A kitchen in the north is most dangerous. This being Kubera's place the expenditure increases like anything beyond expectations.

**18.** The kitchen in night should be well cleaned and used utensils should be cleaned before sleeping.

**19.** Give sacred offering to fire of the first thing you prepare in it. It will ensure peace & prosperity in the house. ■

## **DINNING ROOM**

**1.** Dining Room in west is the best. In the North or East it is the second best.

**2 .** While eating the main person of the family should face the east while the other members may face the east, north or west; but they should not face south because it will cause small disputes.

**3 .** In Dining Room the doors should be in the East, West or North.

**4 .** The shape of Dining Table should not be round, oval shaped hexagonal or irregular shaped. It should be square or rectangular. The Dining Table should not touch the wall or it should not be in folding against the wall.

**5 .** Water should be in northeast of the Dining Room.

**6 .** Wash basin should not be in the southeast or northwest; it should be on the north or east sides.

**7 .** There should be no attached toilet to the Dining Room but place for washing clothes and utensils can be provided.

**8 .** The main door of the house and of the Dining Room should not face each other.

## **PUJA GHAR**

1. The Pujaghar in the building should be in the east, the north or the north-east corner.
2. Puja room should not be in the south direction.
3. Pujaghar should not be in the bedroom.
4. The idols should be in the east and the west of the Pujaghar. The faces of the idols should not be in the south.
5. Pujaghar should not be above, below or next to the toilet/kitchen.
6. White or light yellow marble work in the worship room is auspicious. The colour of the walls of the worship room should be white, light yellow or light blue.
7. The worship room should have doors and windows in the north or the east.
8. Lamp stand should be in the south-east or east corner of the worship room.
9. If the worship room is of the shape of a pyramid (slope on all the four sides of the roof) it is auspicious.
10. Women should not enter the worship room during the menses period.
11. The Agnikund should be in the south-east

direction of the worship room. The sacred offerings to the fire should be made with the face towards the east.

**12.** The showcases and Almirah in the Pujaghar should be towards the western or the southern wall.

**13.** Scenes from the Mahabharat, photographs of birds and animals should not be in the Pujaghar.

**14.** The idol should not be exactly in front of the entrance gate.

**15.** The Pujaghar should preferably have a threshold.

**16.** The idols in the worship room should not be in a desecrated form.

**17.** The idols should not be kept at a place obtained by chiselling off the wall or touching the wall. They should be kept at least an inch away from the wall.

**18.** Pooja room should be avoided in a store.

**19.** The worship room should have a two shuttered wooden door. It should not be made of the Gum Arabic tree or any inferior quality of wood. In the upper half of the worship room there should be space for ventilation or it can be made of glass. Proper ventilation should be there. ■

## **LIVING ROOM OR DRAWING ROOM**

- 1.** Living room should be in the East (leaving the south-east corner) or in the north. However, it is more beneficial in the north.
- 2.** The slope of the flooring of the living room should be in the east or in the north.
- 3.** The door of the living room should not be in the south-east or the south-west direction. The eastern and the western doors are very auspicious for the living room.
- 4.** The internal furniture, show cases and other heavy articles should be in the west or in the south direction.
- 5.** The sitting arrangement of the head of the family should be facing the east or in the north direction.
- 6.** As far as possible TV should not be in the north-east or the south-west corner. It should be in the south-east corner. If it is in the north-west corner a lot of precious time is lost. If the T.V. is in the south-west corner frequent breakdowns are expected.
- 7.** The telephone should not be in the south-west or the north-west corners. It should be in the east or in the south-east or in the north.

- 8.** The Indian style sitting arrangement should be in the east, the west or the north.
- 9.** It is better if the portraits of the God or water falls are hung in the north-east corner. Stuffed animals should be in the north-west corner.
- 10.** The colour of the walls and the tiles used in this room should be white, yellow, blue or green. As far as possible it should not be red or black.
- 11.** Portraits of angry birds, animals, women, weeping children, scenes from the wars etc. should not be displayed in the room.
- 12.** Furniture of this room should not be circular, triangular, egg shaped, hexagonal or odd shapes. It should be square or rectangular.
- 13.** Due to paucity of land, if the furniture is to be kept in the east or in the north direction, it should not be in the direct contact with the flooring. It should be light and hollow and placed on base 1 to 3 inches above the floor.
- 14.** The ceiling of this room if slanting towards the east or the north, is good.
- 15.** The cooler should be in the west/north west/east and not in the southeast direction.
- 16.** In the modern architecture the height of the living room is more up to double than that of the other rooms. There is no harm in doing so. However, the staircase should be in the south, the west or the south -west corner of the room. ■

## **BED ROOM**

- 1.** If the plot is big and spacious, leaving the north-west part of the north side and adjacent to the living room the bed room should be located.
- 2.** In the northern bedroom the morning sun rays are available to some extent.
- 3.** If in the north side bedroom, you sleep with your head towards the east or the south, you can enjoy a sound sleep.
- 4.** A west side bedroom is the best for children. An eastern bedroom can also be used for unmarried children or for guests.
- 5.** If the bedroom is in the south-east direction of the main building, it results in unnecessary quarrels between the husband and the wife. Wasteful expenditure increases and one has face one kind of trouble or the other. It can be used as office or for bedroom of a unmarried son.
- 6.** The north-east is the direction of the deities therefore, no bedroom should be in this direction. Otherwise, one has to face many calamities, sickness increases. If a married couple sleeps in N/E room, they have to face long lasting diseases.
- 7.** Nobody's bedroom should be exactly in the middle of the building.

**8.** The colour of walls should be light rose, gray, blue, chocolate, green etc. Marble stones (white and yellow coloured) should not be used in the newly married couple's bedroom.

**9.** In the main south-west corner of the south-west side, bed room, heavy articles should be kept. The bed in this room should be to the south or the west of the south-west corner of this room.

**10.** Sleeping with legs towards the east gives name, fame & prosperity. Sleeping with legs towards the west gives mental peace & increases a liking for spiritualism. Sleeping with legs towards the north, increases wealth and prosperity. However, if you sleep with legs towards the south, you will not have a sound sleep. There are dreams, bad thoughts crop up in the mind. Heaviness in the chest is felt sometimes. The south is known as the Yamasthan (Place of Yama). Dead body's legs are kept towards the south. Mental sickness increases and there is a likelihood of reduction in the life span.

**11.** Some buildings do not get proper & exact east-west and north-south directions in their building. They get the East-West and North-South in corner or not parallel to the plot. However in bed rooms of such buildings, for getting the proper direction, one should not put his bed in an oblique position S-W, S-E. They should place bed properly in that zone.

**12.** The dressing table in the bed room should be to the east of the north direction. The reading and writing work should be done in the west of the bedroom. It



can also be done in the east. While reading one should face East.

**13.** Television, heater and electrical appliances should be in the south-east corner of the bedroom. The wardrobe should be in the north-west or the south-west of the room.

**14.** The door of the bedroom should be of one shutter as far as possible. It should be in the east, the west or the north. There is no harm in having small windows in the east and the north. Almirahs, showcases etc. should be in the south or the west walls. A mezzanine on this side is tolerable.

**15.** The south-west, west corner should never be kept vacant.

**16.** If bathroom, tub bath, toilet, change room etc. are to be attached to the bed room, they should be in the west or the north side.

**17.** As far as possible, the safe should not be in the bed room. If it is, it should be placed in a way leaving the south-east, the north-east, the south-west and the north-west corners as well as the east and the north directions. If the safe is kept in the south and opens in the north, it is very auspicious. But safe should not be kept towards the north in any room because it opens towards the south, leading to unnecessary expenditure and loss of wealth.

**18.** Keeping mirror in bedroom specially in newly married couple can cause differences among the couple. T.V. & computer should be better to avoided in the bed room.

**19.** If still mirror is required it should be on North, East or N/E wall, placed so that no part of your body will reflect in the mirror while sleeping otherwise same part must have some problem.

**20.** Install a Bagua outside your bedroom door to protect it from negative energy.■

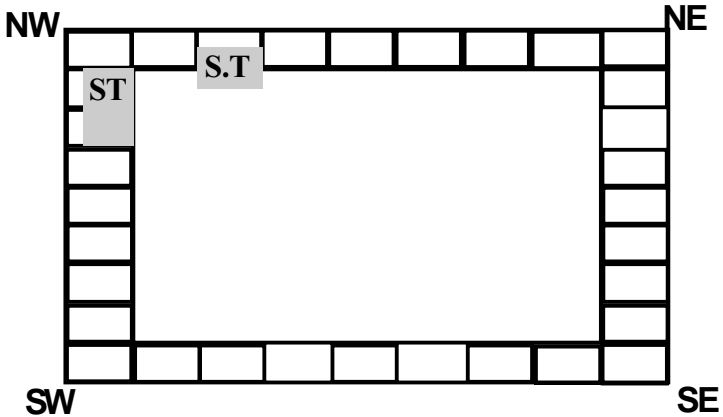
# **TOILETS**

NW	✓	N X	✓	NE X
✓				✓
W X		Center X		E
SW X	✓	S X		SE

1. The W/C should not be provided above or under Pooja room, fire and bed place.
2. The facing of W/C be preferably on N/S axis.
3. The toilets in the building should never be in the centre, the north-east, and the south-west corners.
4. The toilets should be constructed to the west of the building or the north-west side of the north or the south directions, leaving the south-east and the south-west corner. But septic tank should not be in the south.
5. The pot in the toilet should be in the west, the south or the north-west side of the west.
6. The construction of the toilet should be such that the persons sitting there have their faces towards the north or the west.

- 7.** The toilet should be one or two feet higher than the ground level. The door of the toilet should be in the east or the north direction as far as possible.
- 8.** The water storage or the taps in the toilet should be in the east, the north or the north-east corner. It should never be in the south-east or the south-west direction.
- 9.** The slope of the flooring of the toilet and the outlet should be in the east or the north.
- 10.** The colour of walls of the toilet can be according to ones own choice with light colours.
- 11.** In the toilet, there should be a small window, in the East, the West or the north. ■

# SEPTIC TANK



1. SEPTIC Tank should not be in the south-east, the north-east or the south-west corner under any condition.
2. If the north side is divided into nine equal parts it should be in the third part from the north-west direction.
3. SEPTIC tank should not be directly touching the compound wall or the plinth of the house. It should be at least 1 or 2 ft. away.
4. Due to paucity of space, septic tank can built in the north corner of the west side but 1 or 2 ft. away from the compound wall.
5. The length of septic tank should be east-west and the breadth should be south-north as far as possible.

**6.** Septic tank should not be higher than the plinth level of the building. It should be at the ground level as far as possible.

### ***EFFECT OF Septic TANK***

(1)	IN NORTH	Loss of Money
(2)	IN NORTH-EAST	Loss of Business
(3)	IN EAST	Loss of Fame
(4)	IN SOUTH EAST	Loss of Wealth
(5)	IN SOUTH	Loss of Wife
(6)	IN SOUTH WEST	Loss of Life
(7)	IN WEST	Loss of Mental Peace

**7.** The outlet of the septic tank should be in the north or the west. ■

## **DRAINAGE PIPE LINE**

- 1.** The pipelines of the bathroom and the kitchen should have an outlet in the east or the north direction.
- 2.** Outlet should not be in the south under any condition even by mistake. If at all it is, in the south it should be turned to the east or the north direction.
- 3.** The pipes of the toilets and bathrooms should be diverted to the west or the north-west and then the outlets should be given.
- 4.** Drainage pipes coming from upper floors should not be in the south-west corner.■

## **VERANDAH**

- 1.** No corner of the Verandah should be cut off or rounded off.
  
- 2.** Verandah should be on the East or North side.
  
- 3.** The height of the Verandah should be slightly less than the floor level of the entire house.
  
- 4.** The Verandah should never be in the South and West. If so, in the evening or night family should not gossip there nor should talk loudly. It may cause reduction of the family.
  
- 5.** The height of the Verandah should be slightly less than the height of the entire house. ■



## **STUDY ROOM**

1. While studying one should face the East or North.
2. The windows in the Study Room should be in the East, West or North wall.
3. The racks for books should not be in the SouthWest or NorthWest corners. If they are in NorthWest corner, books will be stolen and if in SouthWest they will not be much in use. So in a small cupboard in the East and North the books should be kept.
4. Except the SouthWest and NorthWest a study room in the West is the best.
5. The doors of the Study Room should be in the NorthEast, North, East, West & avoiding SouthEast, NorthWest and SouthWest corners. ■

## **STRONG ROOM**

- 1.) In the Strong room doors in the SouthEast, SouthWest, NorthWest and South should be avoided.
- 2.) The cash almirah should not be kept on a solid platform. It should solidly stand on a levelled floor.
- 3.) There should be only one door to the Strong Room of two shutters.
- 4.) The North being of 'Kuber' the Strong Room is advisable to be in the North.
- 5.) In the Strong Room doors on the East or North walls are very favourable. The cash almirah should not be kept in front of the North door, but it should be shifted away from facing the door.
- 6.) In the cash almirah, costly articles, gold, Silver and jewelry etc. should be kept on the West or South side.
- 7.) If cash almirah is kept in the NorthEast, there will be loss of cash.
- 8.) The cash almirah should be placed on its legs.
- 9.) In the Strong Room leaving 1" space on the South wall and avoiding the SouthEast and SouthWest corners, if the back of the 'Tijori' (Cash almirah) is kept towards South wall while opening the almirah, it faces the North; it is the best position.
- 10.) A small window should be provided in the East and North wall at a higher place.■

## **BASEMENT / CELLAR**

- 1.) A sick person should not reside in Basement. He will not be cured.
- 2.) If business is carried out in Basement, only invoices can be made there but cash counter must be on ground floor and not in the Basement.
- 3.) In Western countries big mirrors are used to reflect the sun rays into the basement. It helps to some extent.
- 4.) The Basement blocks the solar rays and thus deprives the benefits of solar rays. Hence it is advisable not to have basement.
- 5.) The Basement should not be in the South or West alone.
- 6.) East and North Basement are good. If only in the North-East Borewell or water facilities are provided it will be very auspicious and will bring a lot of property. Keeping heavy items in the South-West if one sits facing the North it is very good for business. If business is in the NorthWest a big ventilation should be provided in the North. Any basement should have doors and windows in the North and the East. The business in the NorthWest will be good but there will be laziness and sudden loss in business and theft may occur.

- 7.)** A hotel in the Southeast of the Basement will be successful if the kitchen is arranged as per rules of the Vastu Shastra.
- 8.)** The lower most part of Basement under a temple is full of magnetic power and other powers created by Saints who worshipped there.
- 9.)** No basement should have height of less than nine.
- 10.)** The place at Basement is good only for godowns. If in the SouthWest corner a well or borewell or underground water storage is made it will be most dangerous. The head of the family may have accidental death or suicidal cases may occur.
- 11.)** If 1/4th of the basement is above the plot level and if the morning sun rays enter the basement from 7 am. To 10 am. it is O.K. ■

## **FIRST FLOOR**

- 1.)** The height of the roof of the First Floor should not be more than that of the Ground floor.
- 2.)** There should never be a balcony on the First Floor in the SouthWest corner. It may be away from this corner. Provided it is not round or of irregular shape.
- 3.)** Rain water on the First Floor should have an exit in the North, East or NorthEast.
- 4.)** In the case of only First Floor it should be constructed in the South-West side and only terrace should be left in the North & East. This does not apply to a Multi-storeyed building. Balconies should be in the North & East.
- 5.)** The slope of the flooring of the First Floor should be towards the North and East.
- 6.)** Doors and Windows on the first floor should be on the East and North side. A big window in the Northwest is good.
- 7.)** On the First Floor bedroom or Study room of the head of the family should be provided. ■

## **STAIR CASE**

- 1.)** In a house steps should be in the South, West or South-West. Never on the North-East side.
- 2.)** Never keep cash almirah below steps.
- 3.)** The first step of the stairs should not be round.
- 4.)** The steps should never start or end from the Pooja Room, Strong room, Store room, or Kitchen.
- 5.)** For shortage of space and open space, steps can be constructed in the South-East or North-West. It may affect the health of children slightly.
- 6.)** If possible circular steps should be avoided.
- 7.)** There should be roof with slope on the East or North on the top of the steps.
- 8.)** The room, where the steps of the South-West end, should not be occupied by anyone. If so he will become sick, will have breathing problem; blood circulation will become slow and will suffer from a disease for which medicine will be difficult to avail of.
- 9.)** The steps for going to upper floors and going to a cellar should not be the same.

**10.)** If steps are in the North-East, there will be financial losses, and business losses. The head of the family will be in debts.

**11.)** The steps should be such that one should climb towards the West or South and while descending one should descend towards the East or North.

**12.)** Preferably while climbing up the steps, they should be clockwise.

**13.)** The steps should never be in the Centre of the house.■

## *Garden*

Your garden must be planed with same attention you pay to the inside of the building, If it is to contribute to the balance and harmony of your home. Observing the rules of Vaastu in designing your garden will enable you to balance the positive and negative energies of you property . This is because buildings, with their wood, concrete, steel, bricks and other solid construction material are negative, while earth, plant, flowers and pond are positive. The plant in the garden should be evergreen so that it will provide uninterrupted protection. They should be healthy and green if this is not, they can attract negative energy with their sickly nature.

Fountain with flowing water, create and abundance good positive energy. The movement of water attracts energy, the flow of water symbalizes cash flow and does much to encourage prosperity. Pools and ponds are excellant for positive energy especially if they contain large healthy fishes. Gold or silver fish representing gold and silver coins are important prosperity symblos.

If you have a pool or a pond it should curve towards your building so that the water appears to embrace it. In this position the water will protect that building. If it curves, away, the water will fall and unlucky arrow with negative energy will point to your direction. Mix, shapes and sizes of plants in your garden so that no one tree or plant is grouping over the other. This is an elements of balance.



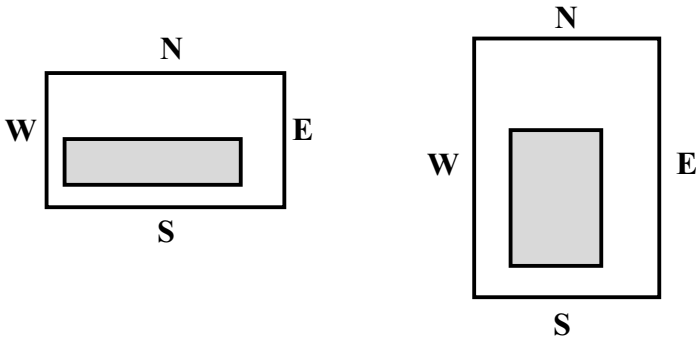
Paths should curved gently through your garden for a natural movement of energy. But they should never be twisted or spiral as these shapes suggest snakes in any garden. A densely planted garden flowers will be less interesting to the eye than one with few interesting plants. Above all your garden should look as natural as possible. Good plants keeping the light closed for e the house is very important than its overall appearance. By attracting and helping to circulate good positive energy, a plesant exterior to your home will be an important element in the overall quality of your home positive energy.

The forces that play a roll in shapping our life are first comes destiny, 2nd is luck, 3rd is Vaastu principles 4th is philanthrophy & 5th is education. By putting Vaastu Principles to work in your home, you will be assisting your family in acheieving financial, acadamic, or relationship. Using the principles of Vaastu you will make your home a welcome places for guests and first step towards philanthorapy will pay off.■

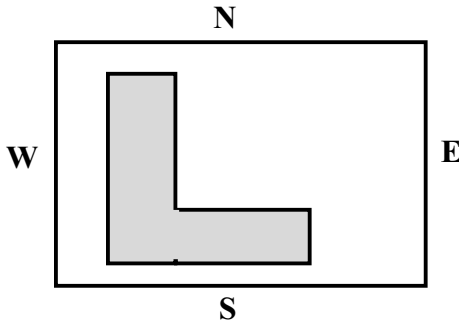
\*\*\*\*\*

## 25. I, L, U, E SHAPE BUILDING

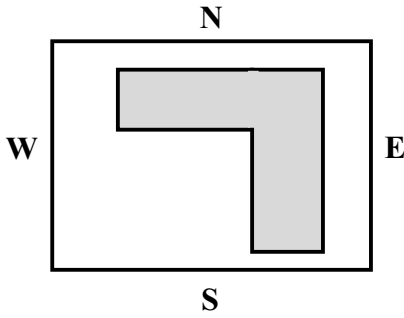
In public Building i. e. Schools, College, Hostel, Hospital, Govt. offices, Commercial complexes & Hotel Buildings constructed in different shapes like L, E, U, C, or H. In this chapter we discuss which shape are not good, if the Building is constructed in one part only than it should be constructed on the South -West part of the plot leaving open space towards North, North East & East.



If the Building is to construct in L shape than it should be towards South West corner. If it is will give best result.

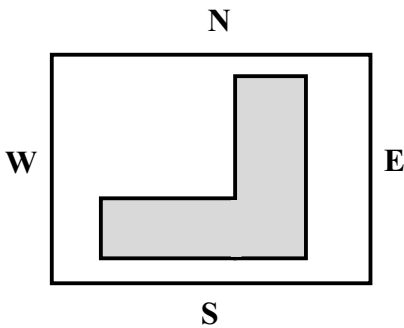
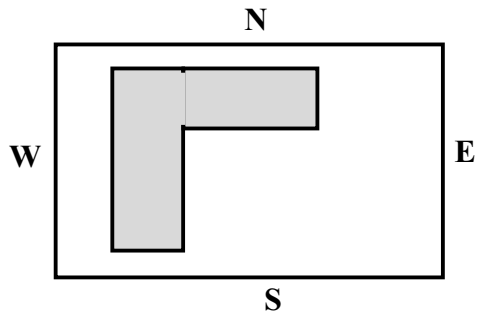


If L Shape building is made as under than it will give negative results.



Covering N E area leaving South West open cause loss of money sudden death.

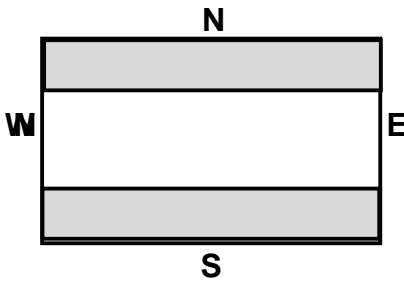
Covering North-West and leaving South -East open, problems & fear of death.



Covering South -East and leaving North -West open. Sis appointments & Obstruction.

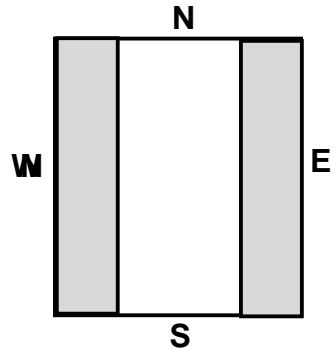
Covering North, North-East North -West & South - East, South & South -West, leaving centre,

Covering North -West, West, South -West & North -

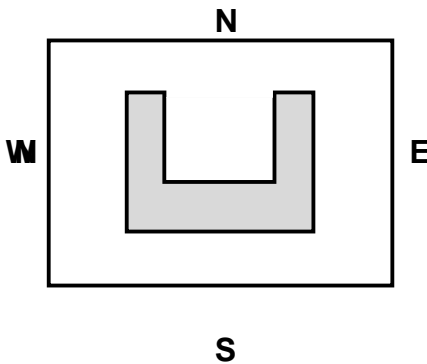


West & East vacant disturbance between brothers family disputes mental tension.

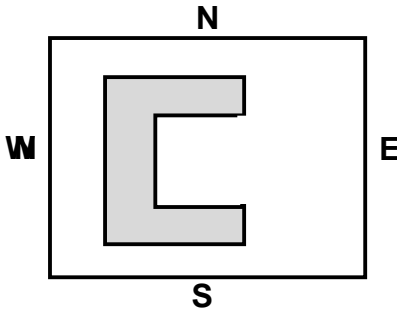
East, East, South East leaving vacant centre. South & North it cause money loss and disturbance.



### 'C' Shaped Building

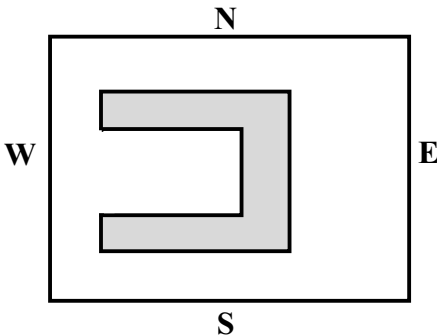
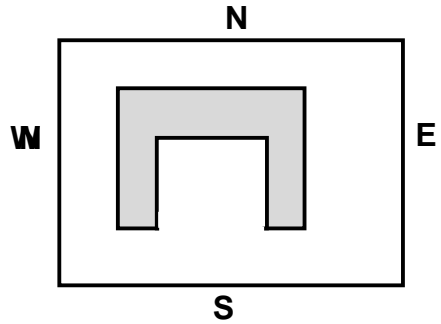


This 'C' Shape building in which North -West, North, North -East is open is the best building.



The 'C' Shape building is good as East & North-East in this is open.

This reverse 'C' Shape Building is in auspicious as North. North -East & East is closed. This result is poverty and tensions.



This reverse 'C' Shape very in auspicious as North, North-East, East & SE is closed. It cause money loss, Enemity and affect the progeny.

\*\*\*\*\*

## 26. FACTORIES

---

---

- 1.) Factory premises should be square or rectangle (1:2) proportion is preferable the Northwest and South West corners should be at 90°.
  
- 2.) The South and West compound wall of the premises should be made of stone and other heavy items, making South West corner exactly to 90°. The east and North boundaries can be of barbed wire also. The idea is that it should be light in weight.
  
- 3.) The well, borewell, underground water storage, garden etc. should be in the East, North or North East.
  
- 4.) In the South East corner, leaving 2 ft. to 3 ft. from the compound wall a transformer room can be made. Also servant, watchman's room can be there without touching the walls.
  
- 5.) In the SouthWest corner scrap and other heavy items can be dumped.
  
- 6.) In the West main office, Laboratory, Administrative office can be arranged.
  
- 7.) Servant quarters may be in the NorthWest corner.

**8.)** The main plant should be in the SouthWest corner.

**9.)** Water source should be in the Northeast. The level of the plot should be low in the Northeast.

**10.)** Heavy Machinery should be in the South side and lighter machines can be installed in the North side.

**11.)** Boiler, Fire and electrical items should be in the SouthEast corner. Raw materials, store room, Waste material etc. should be in the SouthWest corner.

**12.)** Finished goods should be kept in the NorthWest corner. Delivery should be given from a door in the North side.

**13.)** The overhead tank should be in the SouthWest or North West.

**14.)** Parking should be done in the North or East.

**15.)** Main entrance should be in the East or North. It should never be in the SouthWest. West entrance is OK.

\*\*\*\*\*

## **27. BANKS**

---

- 1.)** They should be facing the East or North.
  
- 2.)** Cash to be given should be from the West or North direction.
  
- 3.)** The Manager's cabin should be in the SouthEast and he should face North while sitting.
  
- 4.)** Enquiry counter should be in the East.
  
- 5.)** The slope of the flooring should be towards North or East.
  
- 6.)** The other staff in the bank should occupy the West.
  
- 7.)** The main room of the cash, lockers, and safe room should be in the South and should open towards North or East sides.
  
- 8.)** Drinking water should be in the East , North or North East.
  
- 9.)** The toilets in the bank should be in the West or North West.



**10.)** The stair case should be on the West, South West or South East sides.

**.11.)** Old records, unwanted letters, and files etc., should be kept in the South West.

**12.)** Parking should be done in the East or North.

**13.)** Loan distribution should be done in the East or North.

**14.)** Cash should be stored in the middle counter of the North.

**15.)** The main entrance should be in the North, North-east or East but never in the SouthEast, NorthWest or SouthWest.

**16.)** The meeting hall should be on the West side.

**17)** Cash counters should be in the North, and only cashier while sitting should face the North or East and the cash box should be along South and should open towards North.

## 28. EDUCATIONAL INSTITUTES

---

---

- 1.) Roads should be on the East or West of the building.
- 2.) The entire plot corners should be at 90°.
- 3.) Almira containing stationery should be kept in the South or West.
- 4.) The library should be in the West.
- 5.) Main entry should be from the East or North East. It should never be in the South or Southwest corners.
- 6.) The construction of the building should be in the Southwest or South portion of the Plot.
- 7.) The office of the Educational Institute should be in the South East and the entrance towards the East or North.
- 8.) Class room should be square or rectangle with 1:2 proportion.
- 9.) If possible there should be no beams and cross beams in the class room. This will create unwanted magnetic fields with which students will be less intelligent.
- 10.) The entrance of the class rooms should be in the East, North or North East but it should never be in the South West corner.

- 11.)** Staircase shall be made in the North West, West, South West, South or South East of the building.
- 12.)** The laboratory should be in the West with entry from the East.
- 13.)** Store room should be in the North West.
- 14.)** Toilets, bathrooms should be in the West or North West.
- 15.)** Underground water tank should be in the North-East or North.
- 16.)** The flooring slope should be towards the East.
- 17.)** The Principal's cabin should be in the South West, West or South East. The door should be in the East or North-East to the cabin.
- 18.)** Dead stock should be in the South West or West.
- 19.)** Conference Hall should be in the North with entrance towards the East side.
- 20.)** Open playing ground should be in the North or East.
- 21.)** Well or borewell should be in the North East corner.
- 22.)** The table for admissions and cash counter should be arranged in the office facing towards North.

\*\*\*\*\*

## 29. HOSPITALS

---

---

- 1.) Operation-theatre should be in the West, While lying on the stretcher, patient's head should be on the south side. The doctor should operate facing East or North or west side but never to south side.
- 2.) The slope of the flooring should be towards North, East or Northeast sides.
- 3.) The middle portion of the hospital should be open to the sky. In case of any roof the ventilated roof should be 2 ft. to 3 ft. higher than the top floor roof.
- 4.) It should face the East possibly and the entry should be in the East or Northeast.
- 5.) An emergency case, or serious case should never be kept in the SouthWest corner room. Patient should be kept in NorthWest.
- 6.) The racks for medical books and medicines should be in the South or West.
- 7.) Parking should be done on the East or North sides.
- 8.) Drinking water should be kept in the Northeast.

- 9.)** Cleaning, changing rooms, toilets should be on the South or West sides.
- 10.)** Bathrooms should be on the East or North sides.
- 11.)** X-Ray room, Electrical equipment etc. should be in the SouthEast room.
- 12.)** Cash counter should be in the South or West and should open towards the North or East.
- 13.)** Nurse's quarters should be in the SouthEast or NorthWest place to the Hospital.
- 14.)** Examining patients should be done in the North room. While sitting, the doctor should face the East or North. Patient should lie down with head in the South or West or East.
- 15.)** The patients rooms should be on the South and NorthWest.
- 16.)** Inquiry counter should be in the SouthEast and waiting room on the South side
- 17.)** The Staircase should be in the West, SouthWest, SouthEast or NorthWest.

\*\*\*\*\*

## **30. SHOPS**

---

---

- 1.)** If there are roads in the East and North and if the entrance of the shop is in the North or East a lot of prosperity will be got.
  
- 2.)** The shops with entrances in the South East or NorthWest will give good business for 10 to 20 years. Then the business slowly decreases. (This is the observation of 70% of such shops. 30% shops are exceptions.)
  
- 3.)** The racks of showcases should be in the South and West of the shop.
  
- 4.)** The counters should be in the South, SouthEast, SouthWest, West or NorthWest. But it should never be in the North or Northeast.
  
- 5.)** Maximum furniture should be made of wood.
  
- 6.)** While sitting the customer should face the West or South and the owner or Salesman should face the East or North.
  
- 7.)** Drinking water should be in the Northeast.

**8.)** The electric meter and the main switch board should be in the SouthEast.

**9.)** The owner or the Salesman or the accountant's seat should not be under a beam.

**10.)** The cash counter in the Shop should be along the south wall and should open towards the North or it should be along the West wall and should open towards the East.

**11.)** The goods to be sold immediately should be kept along the North in the NorthWest corner.

**12.)** The counters in a shop should be at right angles (90°) and should not be rounded off.

**13.)** Stationary and Study books will be sold easily along the East in the Book shop.

**14.)** Shops facing the North road will transact good business.

\*\*\*\*\*

## **31. PURCHASE OF THE ADJACENT PLOTS**

---

---

- 1.)** If adjacent plot in the SouthEast, SouthWest, West or NorthWest is available even at free of cost, it should never be taken. It will cause loss of happiness, finance and it will lead to theft and suicide.
- 2.)** If a Nala, or river is flowing from the North or East side, it is very good.
- 3.)** Adjacent plot on the North away from the Northwest will shower money. If adjacent plot in the East and North is purchased, it will bring prosperity and wealth.
- 4.)** If only NorthWest - North is purchased the North West will increase, resulting in loss of business.
- 5.)** If a Northeast plot adjacent to the existing plot is available, it should be purchased immediately even if the rate is higher than the market rate, with this investment the Northeast of the existing plot will increase and will bring plenty of prosperity and finance.
- 6.)** Adjacent plot on the East away from the SouthEast will bring good results.
- 7.)** Adjacent plot towards the south and West of the existing plot should neither be purchased nor be let out. It will cause disputes and loss.
- 8.)** In a residential complex, if a flat on any floor above the existing flat is available it can be taken provided the rooms are as per Vaastu.

\*\*\*\*\*



## **32. PORCH & PARKING**

---

---

- 1.)** The parking should not be in the North-East or Southwest corner. The Northwest corner is best. If in the SouthEast corner constant maintenance will occur. If in the Southwest corner, Car will not come out frequently and it will be out of order frequently.
- 2.)** The Portico in the North or East should have roof level 2' less than that of the entire house.
- 3.)** The pillars of the porch in the North, East or Northeast should not be round.
- 4.)** The gate for parking in the East or NorthWest is best. The height of the gate should be less than the height of the compound wall.
- 5.)** Portico should be in the East or North. If in the West, it should be away from the SouthWest corner. If in the South it should be in the SouthEast corner. This is only 2nd or 3rd grade choice.
- 6.)** Basement of lesser height for parking in the East and North is permissible.
- 7.)** In the porch the Car should face the East or North but not the South. If it faces W, it will stay for less time in the porch i.e. travelling will increase.
- 8.)** If there is a slope towards the North or East for the portico it is beneficial.
- 9.)** Portico or Parking should not be laid on any of the compound walls.

\*\*\*\*\*

## 33. EVALUATION EXERCISES FOR A HOUSE AND FLAT

In this chapter we explain you what is to be placed where. We had given you 10 options in tabular form. So nothing to worry if you are feeling difficult to keep your Master Bed room in S/W zone. It is good in South also. You can evaluate your existing property also according to table and find what score you get.

### POSITION AND LOCATION

**Score sheet for House and Flat :-**

S.No	Questions	Points	Score
1.	What is the position of the Main Entrance/Gate?	10	
2.	Where is the Kitchen?	10	
3.	Where is the Master Bedroom?	10	
4.	Where is the Children's Bedroom?	10	
5.	Where is the Guest-room?	10	
6.	Where is the Drawing or 10 Dining Room?		

S.No	Questions	Points	Score
7.	Where is the Tube-well or Underground Tank?	10	
8.	Where are the Toilets?	10	
9.	Where is the Garage/ Servant's Quarters?	10	
10.	Which direction of the plot is the House built in?	10	
11.	If people were living there earlier, were happy?	10	
12.	If used earlier as an office or commercial purpose, how was it doing?	10	
13.	What is in the SW?	10	
14.	What is the placement or turning of the staircase?	10	
15.	What are the surroundings like?	10	
	<b>Total</b>	<b>150</b>	

## 1. *Position of the Main Gate*

Directions	Points
NE	10
E	9
N	8
NW	7
SE	6
W	5
S	4
SW	3

## 2. *Position of the Kitchen*

Directions	Points
SE	10
NW	9
E	8
W	7
S	6
N	5
NE	4
SW	3

### 3. Position of Master Bedroom

Directions	Points
SW	10
S	9
W	8
NW	7
N	6
E	5
SE	4
NE	3

### 4. Position of the Children's Room

Directions	Points
NW (Girl)	10
SE (Boy)	9
N	8
E	7
NE	6
W	5
S	4
SW	3

## 5. Position of the Guest-room

Direction	Points
NW	10
N	9
E	8
NE	7
SE	6
W	5
S	4
SW	3

## 6. Position of Drawing or Dining Room

Direction	Points
E	10
N	9
NE	8
SE	7
NW	6
W	5
S	4
SW	3

## 7. Position of Tube -well, Underground Tank

Direction	Points
NE	10
E	9
N	8
NW	7
W	6
S	5
SE	4
SW/Centre	3

## 8. Position of Toilets or Bathrooms

Direction	Points
NW	10
W	9
S	8
N	7
E	6
SE	5
SW	4
NE/Centre	3

## 9. Position of Garage and Servant's quarter

Direction	Points
NW	10
N	9
E	8
NE	7
SE	6
W	5
S	4
SW	3

## 10. Position of House vis-a-vis the Plot

Direction	Points
SW	10
S	9
W	8
NW	7
SE	6
N	5
E	4
NE	3



**11. If people were living here earlier, were they happy or unhappy?**

<b>Condition</b>	<b>Points</b>
<b>Happy</b>	<b>10</b>
<b>Healthy</b>	<b>9</b>
<b>Honest</b>	<b>8</b>
<b>Friendly</b>	<b>7</b>
<b>Undivided</b>	<b>6</b>
<b>Unpleasant</b>	<b>5</b>
<b>Sick</b>	<b>4</b>
<b>Quarrelsome</b>	<b>3</b>

**12. How was business for the earlier owner of the office or commercial place?**

<b>Condition</b>	<b>Points</b>
<b>Excellent</b>	<b>10</b>
<b>Prosperous</b>	<b>9</b>
<b>Growing slowly</b>	<b>8</b>
<b>Average</b>	<b>7</b>
<b>Tough</b>	<b>6</b>
<b>In debt</b>	<b>5</b>
<b>Litigation</b>	<b>4</b>
<b>Failure</b>	<b>3</b>

### 13. What is in the South-West?

#### *For a Commercial Place*

Position	Points
Office of CEO	10
Stocks	9
HRD	8
Sales	7
Computer	6
Conference	5
Accounts	4
Toilet	3

#### *For a Residential Place*

Room	Points
Master Bedroom	10
Store	9
Drawing or Dining Room	8
Children's Room	7
Guest-room	6
Servants Quarter/Garage	5
Kitchen	4
Toilet	3

The above is base on a larger perspective to cover a wide spectrum of buildings.

## 14. The Staircase for both Residential or Commercial buildings

<b>Staircase</b>	<b>Points</b>
In the South West, turning clockwise	10
In the South West, turning anti-clockwise	9
In the South, turning clockwise	8
In the South, turning anti-clockwise	7
In the West, turning clockwise	6
In the West turning anti-clockwise	5
In the NW / SE	4
In the N / E / NE	3

## 15. What is there in the surroundings?

<b>Surroundings</b>	<b>Points</b>
More open area in the North/East as compared to the South/West	10
Any natural depression in NE	9
Any elevation in SW	8
Good construction material used	7
Good neighbours	6
Not Close Proximity to any public place	5
Pleasant front view, a good facade	4
Higher prices in the neighbourhood as compared to your plot	3

# YOUR RESULTS

---

---

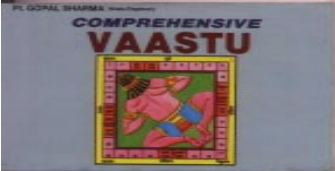
## Rating

Score	Interpretation
150	Excellent
120-149	Very Good
76-119	Good
up to 75	Average

\*\*\*\*\*

**COMPREHENSIVE  
VAASTU**

Price -75/-



*By : Pt. Gopal Sharma, B.E.  
Dr. Dronamraju Poornachandra Rao*

## **34. SOME IMPORTANT SUGGESTIONS**

---

---

- 1.)** The kitchen should not be directly in front of the main door.
- 2.)** Keep all electrical /heat generating appliances in the South East corner of the room.  
Keep no broken mirrors in the house.
- 3.)** Mirrors, sinks, wash -basins and taps should preferably be along the North -East walls and they should not be any leakage from taps.
- 4.)** The safe should open towards the North or the East. So keep it along south or the west.
- 5.)** The toilet seat should preferably be along the North - South axis. The septic tank can be in the North- West or the South East corner of the house.
- 6.)** Avoid having garbage dump, street -light pole, or boulders in front of the main gate or door.
- 7.)** Your main door should not be opposite the main door of another house.
- 8.)** While sweeping the floor with any disinfectant, a little saindhava lavana or sea salt should be added.

- 9.)** Students should study facing the north or east. Do not sit or sleep under a beam other wise mental stress prevail.
- 10.)** Do not hang a painting depicting war, crime, unrest, agony or distress.
- 11.)** Do not have any cactus in the house. Having it outside the boundary is good.
- 12.)** Do not have a toilet or a puja room under a staircase.
- 13.)** Blocking of the North -east (Ishan) portion of the house or industry restricts the inflow of the blessings of God. It leads to tension quarrel and insufficient growth of the inhabitants; especially children of the owner.
- 14.)** In an industry any fault, ditch or broken part in the direction of north - east will get handicapped child to the industrialist.
- 15.)** Improper position of the bedroom/bed brings unhappiness in the married life and causes disturbed sleep.
- 16.)** Having a toilet/fireplace in north - east corner of the house or industry can ruin it financially besides mental tension & quarrel amongst people.
- 17.)** Finished products are to be kept in the North West corner. It would help quick movements of the stock & early recovery there of.

- 18.)** A water body or source should be in the east or North - east of the plot. Having a water body in the south - east /south position of the house can cause damage to the male child/wife of the owner. A under -ground water tank in South - West can be fatal to the head of the family or owner of the industry.
- 19.)** More open space in North or East gives name, fame and prosperity. Leaving more space on the South -West side in the house can affect the male members badly; whereas in industry it leads to financial loss and quarrel amongst partners.
- 20.)** Depression in the South -West can result in to a serious illness to the habitants, whereas depression in north -west causes enmity and litigation. The depression in south portion of the building restricts growth besides financial problems.
- 21.)** Extension in the South -West may result in loss of health, loss of money and other insurmountable problems, whereas an extension in South -East may lead to fire. Accidents, theft, and court litigation.
- 22.)** Heavy machinery has to be installed in South, West and South -West in the factory.

- 23.)** Transformers, generators, motors, boilers, furnaces, oil -engines etc. should be kept in South -East or southern portion of the plot/ building.
- 24.)** Central space is better left open or used for rituals. Kerala's /Rajasthan's traditional four sided house with a central courtyard and verandahs all around, is 'model' of Vaastu design.

\*\*\*\*\*



## 35. AUSPICLOUS COLOURS OF THE BUILDING

With numerology, according to our date of birth, we can find out our auspicious number. While finding the auspicious number only date should be taken into consideration, Month and year are not considered. e.g. 18 -2- 53 Here  $1 + 8 = 9$  is the auspicious number.

AUSPICIOUS No.	COLOURS
1.	<b>Red, Pink, Chocolate, Light Violet.</b>
2.	<b>All shades of Blue, Pink and White.</b>
3.	<b>Ash, Yellowish Green, White.</b>
4.	<b>White, Pearl, Yellow, Safron, Sky Blue, Deep Blue.</b>
5.	<b>White, Indigo, Sky, Light Gray, Pink Orange, Light Green etc.</b>
6.	<b>Ash, Light Yellow, Green, White etc.</b>
7.	<b>All shades of Blue, Pink, Green White etc.</b>
8.	<b>Red, Pink, Chocolate, Light Violet, Orange, Safron, Yellow, etc.</b>
9.	<b>Light Violet, Pink, Safron, Orange, Light Yellow and Red etc.</b>

\*\*\*\*\*

## 36. QUESTIONS & ANSWERS

---

---

**Q. No. 1.** Is Vaastu Shastra applicable to Hindu Religion only ?

**Answer -** No, the principles of Vaastu as enumerated in old classical texts are universally applicable like sun, air and earth. They influence the lives of all human beings irrespective of place religion, cast and creed.

**Q. No. 2.** Is Vaastu applicable to rented houses also ?

**Answer -** The rules of Vaastu Shastra are equally applicable to a self owned or rented premises without bias. For the vaastu deficiencies of a building, both the owner and tenant are likely to suffer. Similarly a Vaastu perfect construction is bound to add to the peace, prosperity and happiness of both parties within few months of construction or occupancy.

**Q. No. 3.** Are the effects of the plot different for men and women ?

**Answer -** In the East N-E, North N-E, West N-W and South S-W of the plots male domination is observed. In the East S-E, South, S-E, West S-W and North N-W direction of the plots female domination is observed. For example those buildings with entrance in East,

S-E direction or the South, S-E direction is found to have female domination. In the buildings with the entrance in the East or the N-E direction have male domination. In the buildings with West S-W entrance the women are always a failure. The women staying in building with North N-W entrance do not like to stay at home. These women are always going out or to outstations. The men staying in the houses with West N-W entrance have always to go outstations or to foreign countries for work. The men staying in the houses with South S -W entrance have no interest in work. They become cruel and lazy.

**Q. No. 4.** How does Vaastu Shastra actually act on human beings ?

**Answer -** The effect of Vaastu Shastra takes place on all the people staying in a building through the following energies.

1. Biological energy of the environment around the building, cosmic energy obtained from the cosmos, solar energy obtained from North and the South pole, gravitational energy obtained from the Earth, water and wind, energy obtained from the nature etc. On the balance of these powers depend the peace of mind and health and progress of a man. If the building is not built as per Vaastu Shastra all these auspicious powers are obstructed leading to the faults in the building.

**Q. No. 5.** If the ground on the N.E is retracted, how it can be made equal to the other sides?

**Answer** - In such a case one may purchase the adjacent plot which is available in the N.E., add it to the main plot and then the N.E may be projected.

**Q. No. 6.** Is there any rule as regards the measurements of rooms ?

**Answer** - The rooms on the East and North should not be bigger than those on the West and South. These rooms may be smaller than or equal to the rooms on the West and South. In the same way, the verandahs on the West and South should be bigger than those on the East and North or equal to them.

**Q. No. 7.** Is it allowed to cover the four corners of the plot ?

**Answer** - It is better to keep all three corners of the house/ temple open excepts S-W, That is why at the time of House -Warming Ceremony, the owners move around the newly constructed house before they enter it. It is considered very auspicious. Although S.W corner may be closed but the open space between the house and the compound wall is a must.

**Q. No. 8.** Is it good to have cellars /basement or underground houses ?

**Answer** - As far as possible it is better to avoid them especially in a residential building, since the houses

should always be on a higher level than that of the road. In olden days palaces generally built on hillocks used to enjoy strength, stability and luxuries of life.

However when the residential as also commercial activities are carried out in the same complex, basement in the East, North and the N-E sector can be made and used for storage and parking. If only basement is used for business, only 60% benefits are obtained in spite of good star position coupled with best of efforts.

**Q. No. 9.** Can the toilet be built on the South West ?

**Answer -** No , it is very bad. If the toilet is built on S-W, there will be mental tension and the eldest male member of the house will fall ill. Either store-room or Master bedroom can be built in this area.

**Q. No. 10.** What is the effect of a toilet in the North -East corner ?

**Answer -** Toilet should not be built on the North -East also, as it is the place of God. So a prayer room, a study room or a bedroom for children may be constructed in this sector. Toilet in NE cause mental tension illness, long lasting disease and bankruptcy.

**Q. No. 11.** On which side should be the stair -case ?

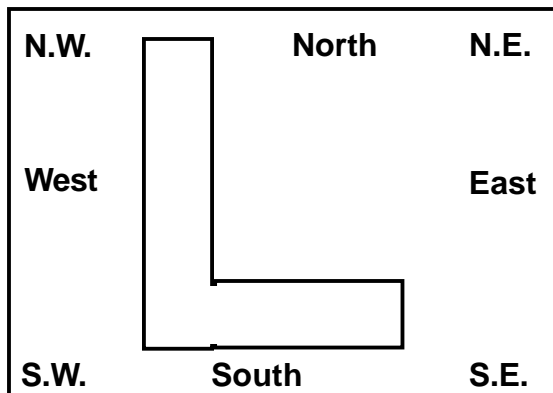
**Answer -** The stair -case may be built on any side except the N.E., in such a way that people might descend from the staircase facing East or North. The area in S-W, South , West, S-E, N-W, North, East should be used in order of priority.

**Q. No. 12 .** Kindly tell where should be the Septic Tank, underground water sump, overhead tank, borewell and open well be built ?

**Answer -** Wells, pits, underground storage of water should be in the NE, North, or East. The septic tank can be in the North or East but not in N-E corner. The overhead tank may be built in the West, S-W, N-W, North or Eastern areas without touching the roof or the parapet wall.

**Q. No. 13 .** What are the demerits of a “L” shaped building ? If necessary , how it should be constructed as per vaastu?

**Answer -** The “Vaastu Shastra “ always recommends that a house should be built in the shape of a square or a rectangle. Of course, out-houses built on the corners may be round. So it is not good, as per the “Vaastu Shastra” to build houses in other shapes i.e. L, U, O shapes. The ‘L’ shaped buildings are constructed with only two sides; thus missing the remaining ones. This is not in accordance with the basic principles of Vaastu Shastra.



If constructing such a building is compulsory, The construction may be started along the South side beginning from S.W. and proceeding towards S.E leaving as less space as possible on the plot in the South. Then another building may be started along the West side beginning from S.W. and proceeding towards the North side wall of the plot. The vacant space between the house on the South and the compound wall must be less than the space between the North wall and the house. In the same way the vacant space between the house and the east wall must be double the vacant space on the West side. In these houses, the level of flooring and the roof of the Southern house must be higher than the level of those on the West.

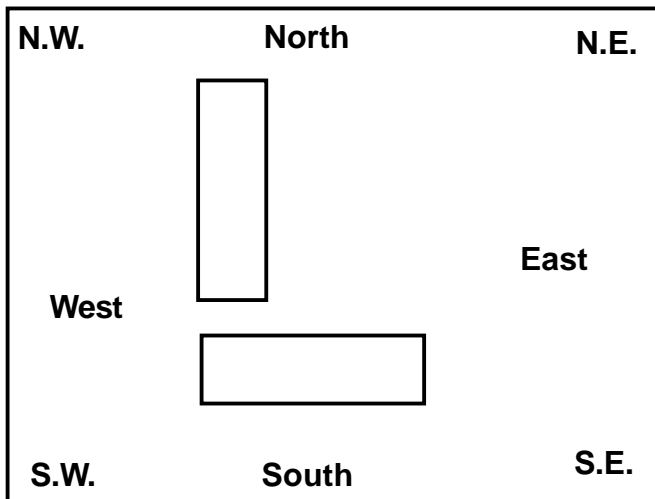
If stairs are to be built on these houses, Verandas must be constructed first on the East and North and then stairs should be built. If stairs are to be built on only one of these two houses, it must be built only on the house on the Southern side. But one should not forget to built Verandas on the East and the North. It should always be noted to see that the level of the house on the South is higher than that of the flooring and the roof of the house on the West.

This is quite correct according to the principle of the Vaastu Shastra. As regards this door ways, elevation & depressions and windows, rules referred to above in the previous pages may be consulted.

Thus construction of the 'L' shaped building on a plot lowering the level on the South and West with both the buildings touching each other in S.W. corner, are not advisable as it causes financial crisis, no issue or, lack of male issue, enmity, accidents or sudden death.

We have observed in large number of cases that violating the rules given above for a 'L' shaped buildings very bad; because in such house the land-lord becomes henpecked,. There are financial losses, delay of the plan, addiction to vices, distress sale of property, and accidents etc.

It is hereby sincerely advised that if at all 'L', 'U' and 'O' or any other irregular shaped construction is a must; a learned Vaastu Expert must invariably be consulted.



**Q. No. 14 .** It is said that the door- ways of a house should be in even number not ending with zero but not in odd number. What is your opinion?.

**Answer -** Yes, it is often said like that; but the door-ways can be in the even number which have a zero e.g. 10, 20 etc.



**Q. No. 15** . What influences most to the living being?  
Please clarify in detail.

**Answer** - The five Elements of nature affect the living beings directly as mentioned below :

**(i) Earth** : If there is no earth, we can not exist. It is only the Earth which makes the country look beautiful with emerald like fields and carpets of green grass; It also emitting oxygen which is so vital for existence.

**(ii) Air** : This is present every where; without air there is no life. The exhale which is emitted from our nostrils is called 'Swar' (voice). No sooner the function of the Swar stops, the living beings die.

**(iii) Water** : The most important thing necessary for life is water only. Around 70% of human body consists of water.

**(iv) Fire** : Each and every living being requires fire. For cooking food or for any sacred ceremony including marriage we need fire. Even the final absorption is not possible without fire.

**(v) Space** : This is a place of storage. It causes rain; deciding when, where and how much rainfall is to be given to the various earth segments.

**Q. No. 16** . Can the defects of construction be removed by Mantra, Tantra, Worship or machines ?

**Answer** - The Mantra, Tantra, worship and the sacred machines increase the auspicious energy and

benefits the buildings. However this auspicious energy does not last long because it is obstructed by the inauspicious energy produced due to faulty construction.

**Q. No. 17** . Should every person purchase plot with roads on the East and the North side road ?

**Answer -** There are no two opinions on the fact that the plots with the roads on the North or the East side are really good. But due to paucity of land it is not necessary that everybody will get a plot with roads on the East or the North side. In the plots with road on the South side the compound gate and the main entrance should be taken in the South-East of the South direction. Plots with roads on the South are very auspicious for Hotels, Steel, Hardware Store, Tyres, Oil, Chemical Engineering, Coal and Beauty Parlour Businesses.

**Q. No. 18** .Do the rules laid down in the “Vaastu Shastra” hold good only in the case of constructing houses or do they apply even to the construction of temples?

**Answer -** The rules laid down in the “ Vaastu Shastra” apply to all kinds of constructions including temples. It applies to construction of houses, granaries, shops, theatres, factories, cattle -shed, huts, buildings, forts and temples etc. Even for a garden, park or club, the rules laid down in the “VAASTU SHASTRA” should be followed.

**Q. No. 19** . While purchasing a plot, what are the dimensions to be taken care of ?

**Answer** - One should take such a plot, all the four sides of which are equal or the N.E. corner of which has a projection. If there are projections on other sides the excess land may be left and all the sides should be made equal

**Q. No. 20** . Is Vaastu Shastra related to Astrology ?

**Answer** - It cannot be denied that Vaastu Shastra is related to astrology to some extent. If in the horoscopes of people the stars Saturn, Mars, Harshal and Neptune are prominent and if the entrance of the houses of these people are in the South they get success in their work. When the stars of the head of the family are prominent he does not feel the effects of the faulty construction to that extent. When the stars of the head the of family are under bad influence the doubly bad effects of faulty stars and faulty construction are to be borne. But when the entire structure is according to Vaastu Shastra and the stars of the head of the family are under bad influence the bad effects are reduced to a large extent due to auspicious energy.

**Q. No. 21** . Does the faulty construction lead to bad health for a man ?

**Answer** - Vaastu Shastra and Biology have a close relationship. The universal, magnetic and solar energy acting in a structure are effecting the body of a man. Mental disorder or imbalance lead to spoil the health

of a person. For health the vacant North-East corner surrounding the building is very effective. In the North - East corner around the house or of the house if there is rubbish toilet or septic tank exists it leads to bad health for men and children of the house. If in the South -East corner around the house or of the house there is rubbish, dirt, septic tank, toilet, well, boring or water tank it leads to bad health of women, little girls.

If there is defective construction in the North -East direction it leads to chest cancer, brain cancer, headache, E.N.T. trouble, pain in teeth and possibility of attack etc. If there is faulty construction in the East Direction, it leads to pain in the left hand and shoulder, rheumatism, sprain in the right hand etc. If there is faulty construction in North direction it leads to pain in left hand and shoulder, rheumatism and sprain the left hand. If there is faulty construction in the South direction it leads to pain in the waist and thighs rheumatism, paralysis and there is a possibility of fracture in left leg. If there is faulty construction in South -West direction it leads to kidney trouble, corner of the uterus, stomach trouble, indigestion, swelling of intestine , diabetes etc.

**Q. No. 22 .** What is the scientific base to the view that one should not do any work under the beam or bar?

**Answer -** The beams and bars are holding the weight of the upper floors. It means that there is tremendous weight on the beams and bars. The weight is acting on the downward direction according to laws of gravitation. This tremendous gravitational force is

working on the person working under the beam or bar. Because of this the person feels uneasy, work is not done properly and it leads to failure in work. At night the part of body which comes exactly under the beam is affected and there are innumerable example of diseases pertaining to those parts which have come to our notice. In reality the main entrance of the building should not be taken under the beam. The students should not study under the beam.

**Q. No. 23 .** Where should the magnetic compass be kept for marking the directions in the plot ?

**Answer -** While observing the direction in the plot the compass should be kept at the exact centre of the plot.

**Q. No. 24 .** The film industry prospered in Mumbai and Chennai. Delhi is a big city, why did film industry not prosper here ?

**Answer -** Delhi mainly comes in North zone. On the other hand Mumbai comes in the South zone in Western part. Since south direction is the direction of entertainment therefore film industry is mainly prospering in South. To the East of Chennai and all around Mumbai is sea, giving the benefits of hydro energy, to these cities.

**Q. No. 25 .** If the main entrance is of two shutters what are the special benefits ?

**Answer -** The main entrance should be of two shutters and it should not be in the corner. It should be

at least at a distance of two feet from the corners. It gives more /early progress by better energy flow than a simple shutter shop /office.

**Q. No. 26 .** If the deity is kept inside the kitchen, is it allright ?

**Answer -** A separate place of worship is always the best. Due to paucity of the space if it is included in the kitchen, it is acceptable. However it should never be under the kitchen platform or the sink. If it is to be taken in the kitchen it should be in North -East, the North -West, the East or the West direction.

**Q. No. 27 .** How and where should the owner sit in his office ?

**Answer -** There are mainly two types of owner.

- A trader who deals in actual delivery of goods.

- A consultant who serves the people with his brain e. g. Doctor, Lawyer, Astrologer, Professor etc.

As per basic guidelines of Vaastu, the owner /CEO should always sit in the room in South or West zone. For more prosperity the trader should preferably sit with face towards the North and the consultants for more name & fame should preferably sit facing East.

**Q. No. 28 .** Why the Taj Mahal at Agra became so famous ?

**Answer -** Mainly Taj Mahal is a square figure. Taj Mahal has four doors in the East, the West, the North and the South. Out of these the doors in the East and

the West are of the same height meaning at the same level from the ground. The south gate is at a higher level than the North gate. The North and the South direction pass from the exact centre of Taj Mahal. It means the magnetic field passes through the centre. The most important thing is that the river Yamuna flows on the North side of the Taj Mahal. The whole building is made of a particular type of marble. The height, the dome etc. are constructed with due regards to Vaastu Shastra. Due to this magnetic force a unique area is created in and around the Taj Mahal, best owing the building a power to attract the spectators from all over the world.

**Q. No. 29** .Thousand of people lost their lives in the Bhopal Gas Case. What construction fault was there?

**Answer -** In the old locality of Bhopal in about 80 acres of land a factory is situated with a name Union Carbide Pesticide Factory. The shape of the plot is irregular. The South, South-East corner is cut whereas the East, South -East corner is extended. The West, North-West corner is also extended. In the same way the North -East and the North direction are totally cut, thus the auspicious directions are cut where as all inauspicious directions are extended. The main entrance of the factory is the South of South-West part. The furnace is at the centre-place . To the South of factory is the storage tank and boring to South -West side. This means that there are pits and water in the South of South -West direction. Railway line has passed through the North and East and the South part of the factory. There is downward shape in the South

West direction. In spite of all these construction faults the whole factory being built against Vaastu Shastra, it continued for a few years in itself is wonder. The main reason is that with downward slope in the East, unnecessary water used to collect there. The methyl isocyanate plant was exactly at the centre of the factory. All types of pesticides were made here. There were three storage tanks Nos. 610, 611 & 619 where MIC was stored. On 3<sup>rd</sup> December storage tank No. 610 get leaked. Due to the poisonous gas more than 2000 workers died and more than 20,000 workers were injured seriously.

**Q. No. 30 .** Why the Western Railway in Mumbai is more profitable than the Central Railway?

**Answer** - The North -South length of the island Bombay is more. The Central Railway passes through the place of Brahma of Bombay city. Therefore the Railway board gets less profit from the Central Railway and even it is not developed to the extent. The Western Railway has passed through the Western part of Bombay. The West is the direction of air therefore fast moving vehicles have progressed in the Western direction. As more sea is on the West of Bombay the western suburbans have also progressed more than the Eastern suburbans.

**Q. No. 31.** Why the Surya Temple at Konark in Orissa not so famous ?

**Answer** - In the Orissa state of India there is a Surya temple at Konark, known as the "Konark Temple". It



could not become famous because of construction faults. The site of Konark Temple is at a lower level than the rest of the surrounding village. The North- North-West and South-South-West part around the temple is extended and the North -North-East and South -South -East portion are cut. This is against the principle of Vaastu Shastra. The Surya mandir temple is constructed in the form of a chariot. Due to this the Eastern part is at a higher level than the rest of the temple, obstructing the name & fame it deserves. Also the East - North -East corners are cut, which deprives the building of any growth.

Adjacent to Surya Temple on the West side is the temple of Chhayadevi in the South-West part, which is also incomplete with a lower height of its base. This means that the South - West part of the temple complex is low. This is also one of the important factors which does not allow sufficient strength to the temple. A Natyashala (Drama School) is constructed to the East of the Surya Temple. Due to this most of the devotees do not pass through the main entrance. In the South-East direction a well is situated because of which the glory is diminishing gradually; giving the rare temple at Konark, a deserted look.

**Q. No. 32.** Which is the main construction fault in the Parliament House at Delhi ?

**Answer -** The Parliament House at Delhi is circular in shape. Since there is always darkness in circular buildings, there will always be a difference of opinion among all the parties. The progress of the nation will

never be thought of. On the other hand the White House of America is rectangular in shape therefore the politics and progress in enviable.

**Q. No. 33.** Why Varahswami Temple, who was the mentor of Shri Balaji, at Tirumal is deserted ?

**Answer -** Varahswami is the teacher (Guru) of Tirupathi Balaji. It is believed that without visiting the temple of Varahswami the visit to Balaji Temple is not fruitful. There is a large water tank and to the North-East of tank, the Varahswami Temple is situated. This means that in the South -West of Varahswami Temple, water is situated. In addition to the South, the South -East and the South -West parts of this temple are at a lower level whereas the market on the North side is at a higher level. All these things are against the principles of Vaastu Shastra. That is why inspite of the announcement and literature emphasizing that it is meaningless to visit the Balaji Temple without visiting the Varashwami Temple, hardly 10% of the devotees visit the later.

**Q. No. 34.** Which principle of Vaastushastra is responsible for the importance obtained by the Vivekanand Temple at Kanya Kumari ?

**Answer -** A brass statue of Swami Vivekanand the disciple of Shri Ramkrishna Paramhans, who spread religion and philosophy , is set up at Kanyakumari. In the Indian ocean in Tamilnadu this temple is situated on a large stone and is famous as a place of pilgrimage. For reaching this temple one has to travel

by motor boat through the sea. After a lighting from the boat for reaching the temple one has to go by a road on The North-East side. The devotees enter the temple through a gate in the North -East direction. Water all around the temple and a North-East entrance are two natural gifts which have made this temple of Swami Vivekanand very famous.

**Q. No. 35.** What are the special features of Ramkrishna Math according to Vaastu Shastra ?

**Answer -** The auspicious river Ganges flows towards the East of the Math. This is special feature. The Western part of the Math is taller and the Northern part is shorter in height. In the East -North -East part of this Math there is a garden. The entrance gate is in the auspicious South, South-East direction. The Ramakrishna Math has prospered due to all these qualities.

**Q. No. 36.** Why is Goddess Laxmi happy with the commercial street at Bangalore ?

**Answer -** The commercial street at Bangalore is in the East -West direction. The downward slope of this road is entirely towards the East. The cross roads starting from the commercial street towards the South and the North have downward slope in the North direction thus they have upward slope towards the South. This business prospers due to the downward slope towards the East and the North. That is why it is said that the Goddess Laxmi is benevolent to this road which is not wrong. The same situation found at Nasik in Maharashtra for Sharanpur road, College road & Gangapur Road.

**Q. No. 37.** Why the colonies of the aristocratic and rich people is in the South of the town ?

**Answer -** Every city has a boundary. As we move South the distance between the North and the South side increase. The North is the direction of Kuber. Kuber has got infinite amount of wealth. That is why people staying on the South side are rich because they get maximum opening for the North direction. In India South Block houses the Prime Minister office & Defence Ministry facing North Block which housing the Finance Ministry.

**Q. No. 38.** Where should be the screen in a cinema house ?

**Answer -** Picture drama music etc are forms of entertainment. South is the direction of entertainment. Therefore it is better to have the screen in the South. As far as possible the screen of a cinema house should not be in the North. Medium level benefits are obtained if the screen is in the East or the West.

**Q. No. 39.** Where should be the stage of the couple in a marriage ceremony?

**Answer -** Every auspicious work should be done with face towards the East only then it is successful. For the stage of the new couple should be in the West to be auspicious. It can be all right if the stage is in the South. However the stage of the couple should never be in the North. If it is in the East medium level benefits are obtained.

**Q. No. 40.** What is the fundamental difference between Indian Vaastu Shastra and the Chinese Feng Shui?

**Answer -** Indian Vaastushastra is based on different forces, cosmic rays, natural laws, the five basic elements different energy sources etc. The Chinese science of Feng Shui does not seem to have given much importance to the directions since one school of thought advocates only “Directionless Feng Shui”. Feng Shui is based on shape, colour, water, hill, photos, light arrangements, mirrors etc. As less importance is given to directions in the science of Feng Shui different meanings are attributed to different building shapes. Feng Shui is applicable more to interior decoration/ placement of furniture and works wonders for flats and apartments.

**Q. No. 41.** Are irregular plots or structures recommended ?

**Answer -** No, The classical works are very clear in stating that the structure should be a perfect square or rectangle.

<b>North West</b>	<b>North</b>	<b>North East</b>
<b>West</b>	<b>Brahma</b>	<b>East</b>
<b>South West</b>	<b>South</b>	<b>South East</b>

According to Brihat Sanhita irregular shapes gives following results :

1. When South East is cut, the owner will lose wealth and will be miserable through women.
2. When the North West is cut there is loss of money and food.
3. When North -East is cut he will fall from virtues.
4. When the South-West is cut there is death of male children, troubles through women and the master becomes servile.
5. On the other hand if all the angles are right the inmates of the house will be happy and live with wealth and honor.

**Q. No. 42 .** Can a portion of the house be rented out?

**Answer -** Retain the South -West portion of the house and rent out the rest. Avoid letting out part of the house at the cost of retaining the North-West portion which could bitter your relationship with the tenant to your detriment. If it is an independent house rent out the total portion.

**Q. No. 43.** The placement of main doors is so confusing. Some say it should be as given in the classical works, some say it differently. How do we decide on the correct placement ?

**Answer -** We prefer to rely on the classical works as far as the main door is concerned. However , in case

where it may not be possible to stick to this because of building constraints modern scholars suggest the following guidelines.

<b>Favourable in</b>	<b>N- NE</b>	<b>E- NE</b>	<b>S- SE</b>	<b>W- NW</b>
<b>Unfavourable in</b>	<b>E- SE</b>	<b>W- SW</b>	<b>S- SW</b>	<b>N- NW</b>

**Q.No.44.** Do you recommend any specific measurement while using mirrors ?

**Answer -** Always go in for square or rectangular ( $L=2b$ ) mirrors. They can be hung on the East or North walls of the house.

**Q. No. 45 .** Can houses be built on road level ?

**Answer -** It is always better to build both the compound floor and the structure above the road level. Let the foundation for the compound floor be at least two feet above the road level, Let the house (structure) itself be at least two or three feet above the ground level. Generally speaking if you observe temples, you will find that they are built on a higher level than the ground. Taking the life of a building as about fifty years, there is always the possibility of the height of the road slowly increasing over a period of time. It is therefore all the more necessary that the structure is built at a higher height to avoid flow of rain water etc. from the road into the building or compound.

**Building level**                          +++)

**Compound Floor Level**                ++)

**Road Level**                                +)

**Q. No. 46 .** What is the relationship between the length and breadth of a building ?

**Answer -** The best is square structure where you have both the length and breadth equal. However this may not be possible in many cases. The rectangular structure is the next choice.

**Brihat Sanhita** states that the length of King’s dwelling should be greater than its breadth by a quarter. For example the following table gives the lengths and breadth which can be used by you for your house. It is to be noted that the maximum length of the building should be twice the breadth and no more.

<b>Propotion of length / Breadth</b>	
<b>Breadth</b>	<b>Length</b>
<b>18</b>	<b>22.5</b>
<b>20</b>	<b>25</b>
<b>25</b>	<b>31.25</b>
<b>30</b>	<b>37.50</b>
<b>40</b>	<b>50</b>
<b>45</b>	<b>56.25</b>
<b>50</b>	<b>62.50</b>
<b>80</b>	<b>100</b>
<b>100</b>	<b>125</b>

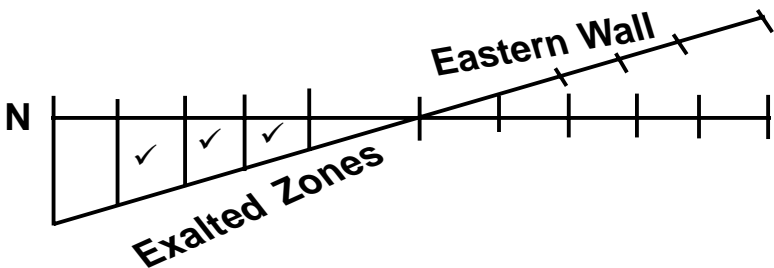


**Q. No. 47 .** What pictures are suitable in a drawing room?

**Answer -** You can have natural sceneries which are pleasing to eyes on your North or East walls. Pictures of smiling children etc. can also decorate your house. Avoid pictures depicting burning forests, fires etc. For strength and stability we should decorate our South-West wall with a picture/wall poster or wall paper of a high mountain peak without water like Alps, Everest or Kailash mountains. A picture of waterfall, a mountain or a tortoise on North wall gives financial prosperity. Photos of departed souls can be hung on the South Walls.

**Q. No. 48 .** How do you define a door when the site and building is tilted 20 degree to the cardinal directions?

**Answer -** Let us suppose you have slightly East facing site on which you construct a house. Find out the centre point of the Eastern wall on the plan. Tilt the plan to the direction the site is facing. Put your compass on it and draw a North -South line passing through the centre of the Eastern wall. Divide the North South line into 9 parts. Draw lines on the 2nd , 3rd , 4th grids to cut the Eastern wall. These are the places at which you can have your main door.



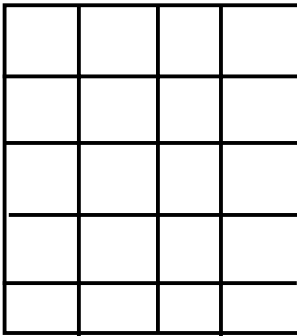
**Q. No. 49 .** What is the significance of keeping plant in general and 'Tulasi' (Basil Plant) in particular in the house ?

**Answer -** The great scientist J.C. Bose proved that plants also have life and respond like any other living being. Plants inhale the Carbon Dioxide and exhale Oxygen during the day whereas they give out Carbon Dioxide and take in oxygen in the nights. Unlike other plants 'Tulasi' has the tendency to exhale oxygen both in the day and night.

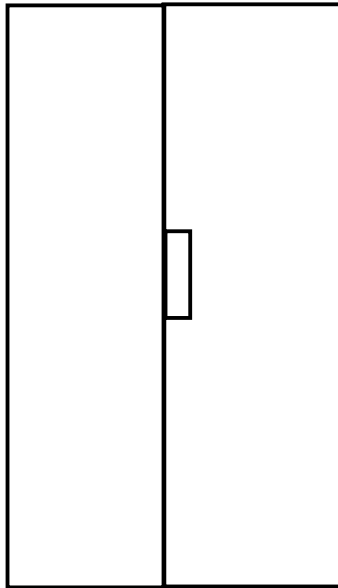
Oxygen coming out from 'Tulasi' purifies the polluted air surrounding the premises of the house. In having such pure air reduce the effect of pollution in the mind. This enables for a healthy thinking process. A positive nature of decision making gets developed. That is the reason, why we find flower pots placed in big conference halls and in office rooms occupied by top executives. The flower plants not only look beautiful but the oxygen exhaled by them reduces the tension and develops a smooth and positive thinking process.

**Q. No. 50 .** Is a peephole through main door advisable ?

**Answer -** As a rule have a small window between the main door and the wall. This will enable the lady of house to have a clear view of strangers passing through the door bell.

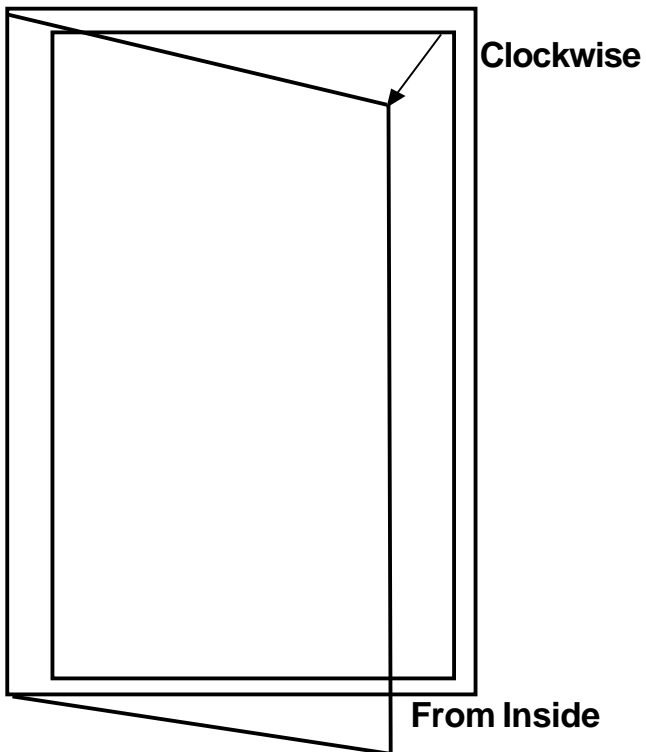


**Window**



**Q. No. 51 .** Is a particular direction for opening the door recommended ?

**Answer -** Yes, the traditional way of pradakshina or circumambulation round the deity is always in the clockwise direction. Similarly when you stand inside the house, the main door should open towards your left, in the clockwise direction. As far as possible apply this principle for the other doors inside the house too.

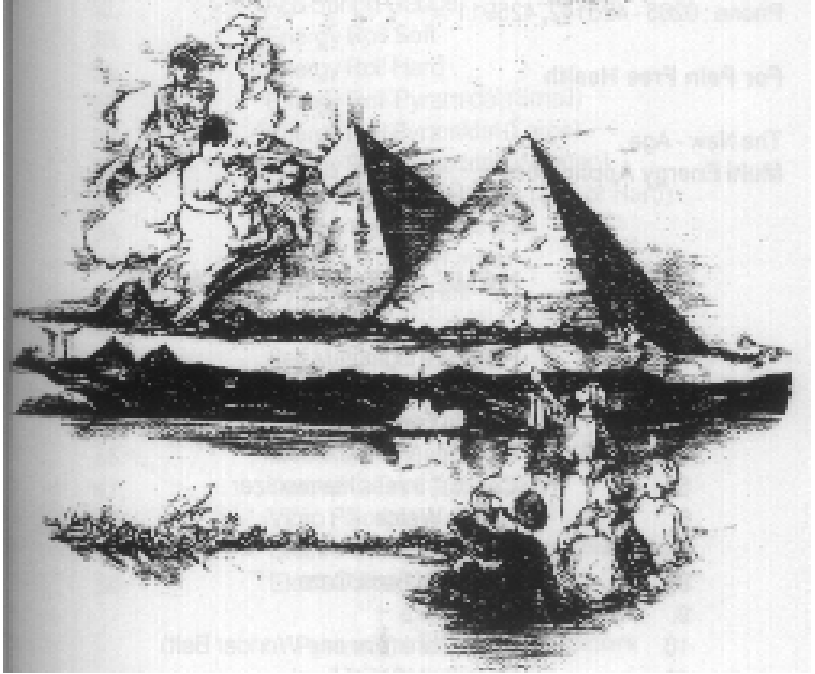


\*\*\*\*\*

## 37. PYRA VAASTU AND PYRAMIDS

---

---



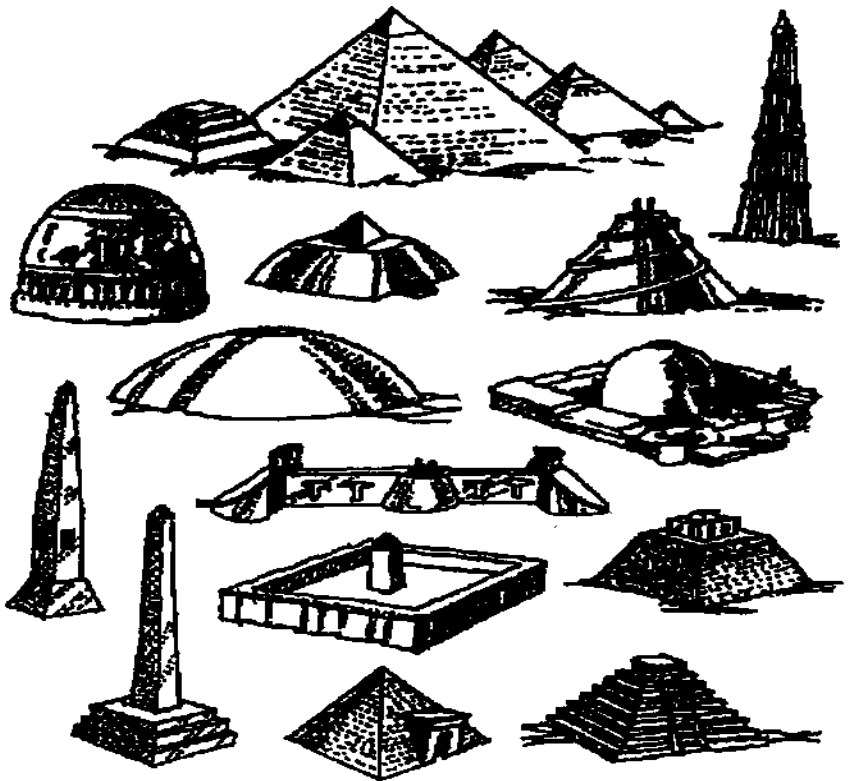
Fire is known as 'Agni ' in Sanskrit language, it has many other meanings too in Sanskrit. The deeper meaning of fire in relation to life force, body or a cell is initiation or Firing, triggering or motivating activity at genetic code at the centre of our floppy disk.

The Egyptian masters had already understood the deeper meaning of 'fire' and had devised the Pyramid

for that purpose. According to them, 'Pyramid' is divided in to two parts 'PYRA and 'MID'.

'PYRA' means fire, indicator at the centre core or nuclei. 'MID' means in the middle.

Though only very little is known about Pyramids today. Pyramid is a scientifically designed instrument with the holistic approach. The complete detailed knowledge of stars, galaxy, sun, planets, earth's dimensions, amount of land and water on earth, rotating speed of magnetic field, gravity, wind, time, space and energy, life force and the aspect of body, mind and spirit is seen in the making of the Pyramid. Its perfect creation owes to this knowledge.



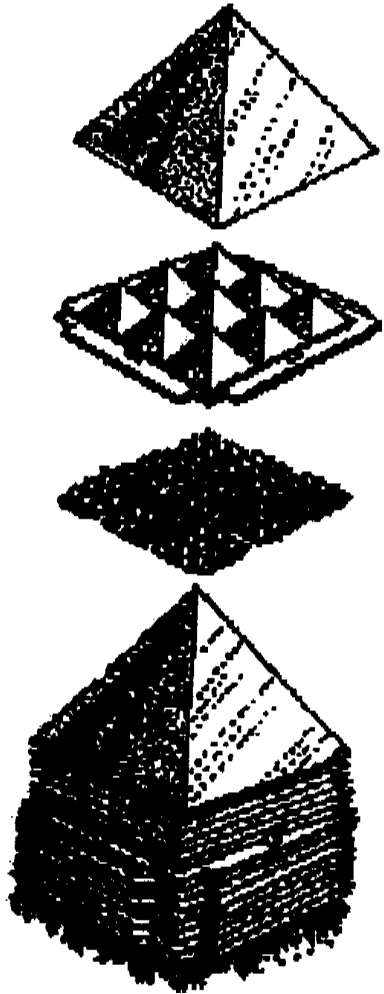
# PYRAMIDAL VASTU

---

All this talk about Vaastu is fine, but can Vaastu be applied entirely to my home or my workplace ? No, because Vaastu is practically impossible in today's life style. It is nearly impossible to adhere to Vastu in cities and metropolitans. Also the popularity and availability of flats and apartments is more, they are sound economically too.

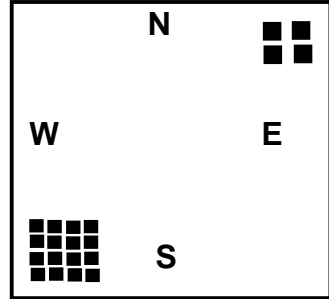
There are many people who really want to use Vaastu but, they have already bought the plot, constructed the house and have come to reside there, they come to know about Vastu -Shastra later. So what should they do? Buy another plot and build a new house according to Vaastu there ? We know this is nearly impossible, But then, here is a way -out too. Pyramid Yantra which is a completely new concept

based on mind over matter. We know that mental level correction is much more powerful than that done in building and material. The new Pyramid Yantra is specially designed to correct your place according to Vaastu, though symbolically. So, now let's learn how to use this new Pyramid Yantra kit 9 x 9. This is prepared from 9 multi layered pyramid each one consisting of 91 pyramids making a total of 819 pyramids.

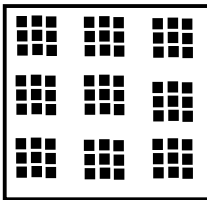


### ***(1) Correction of Slope***

If your slope is not proper according to Vaastu then place four pyramid yantras in the South -West direction for a plot of about 2,500 square feet. But, if your plot is a bigger than 10,000 square feet, then place 16 in North - East and in South -West direction as shown in the figure.



### ***(2) Correction for 8 directions***

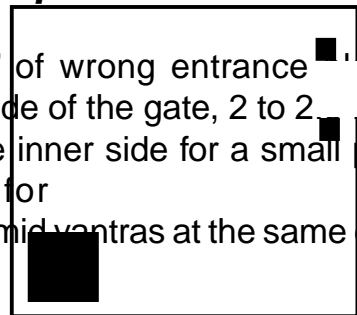


Most powerful method of energizing such a 'dosha' is to place nine pyramid yantras in all the eight directions and nine in the centre for about a plot of 5,000 square feet.

But, if your plot is a bigger one place pyramid yantra in multiples.

### ***(3) Correction at Compound Entrance***

For removing the 'dosha' of wrong entrance pyramid yantra on each side of the gate, 2 to 2 away from the gate in the inner side for a small plot and for a bigger plot place nine pyramid yantras at the same distance.





### **(4) Correction of Shape**

If your plot shape is irregular then place nine pyramid yantras on each of the four corners as to make a

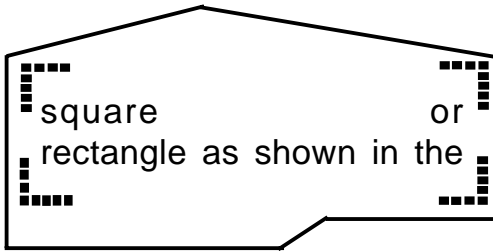
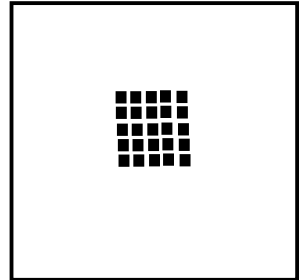


figure.

### **(5) Correction at Brahmasthala**

If your plot has no other defects and it is a one of about 2,500 square feet you have to install Pyramid yantras in the central part of the house

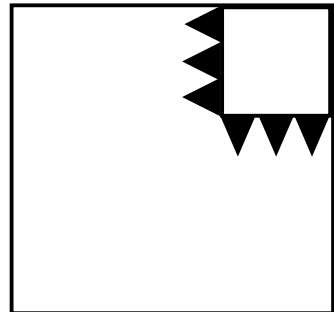
of plot and keep a distance of one foot between them. For a bigger plot of 5,000 square feet place 25 pyramid yantras, place 49 for a plot of 10,000 square feet and so on.



S

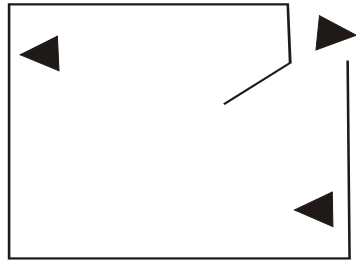
### **(6) W.C. in Wrong Place**

Place three pyramid yantras on each outer side of the wall facing the room for protection.



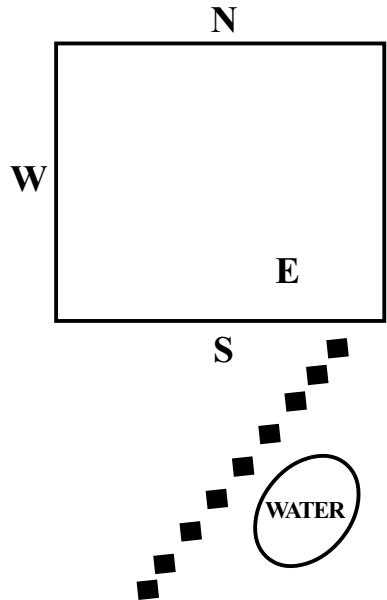
**(7) Correction in Placement of Room**

If your room has a Vaastu 'dosha' place pyramid yantra in the entrance on the outer side room place another one on the same wall corner in the inner side and place one on the opposite wall exactly in front of the entrance door.



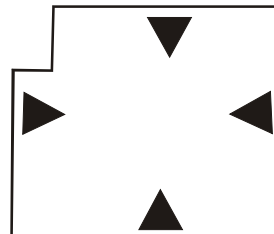
**(8) Protection of Place**

If you have a placement of room in a wrong side or near energy according to Vaastu for e.g. if you have storage of water in South - East (corner for fire ) then place nine pyramid yantras there to nullify the effect. In this way you can always create such a symbolic wall protection if you have some unsuitable energise surrounding you.



**(9) Cut House Corner**

Install one pyramid in all the four direction - N , S, E, and W.



**(10) Main door 'Dosha'**

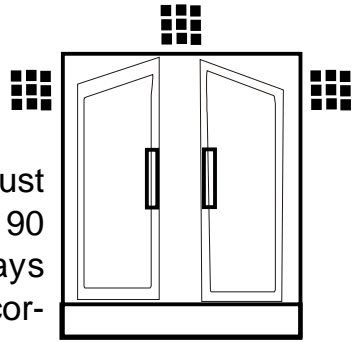
If the main entrance door is not proper place a pyramid yantra in the centre of the door above the frame and each side of the frame as shown in the

**FIRE**

figure.

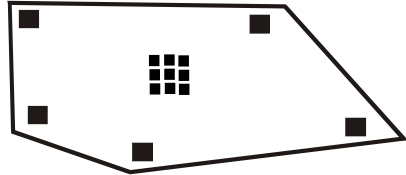
### (11) Right Angle

According to Vaastu the plot must have all its four angles to be of 90 degree, but this is not always possible. If you have a sharp cornered plot correct all its corners by placing one or nine pyramid yantras.

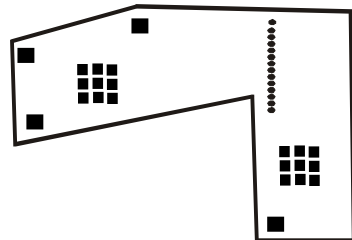


### ( 1 2 ) Brahmsthala Disturbance

There was some irregular shaped plots in which gravitational centre, Brahmasthala does not locate in the shape but outside it. In such cases divide the plot in 2 or more parts by creating a symbolic wall of pyramid yantra and then find their individual Brahmasthalas.



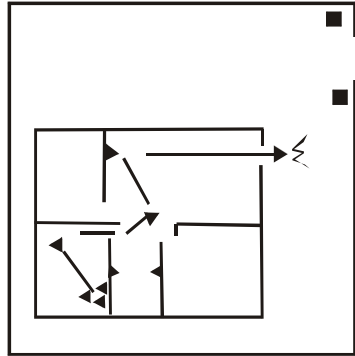
Now, place nine pyramids in the centre and one on each corner of the shape. But, if your plot is bigger one place pyramid yantras in multiples.



### (13) Energy Spread in House

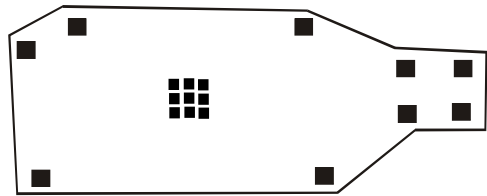
If you want to take good positive energy to any room

of your house you have to follow a path for example. If you want to take the energy to the master bedroom of the house given in the figure, place pyramid yantras as shown in the figure, which shows how to direct the energy into your house through pyramid yantra.



**(14) Irregular Shaped Plot**

If your plot is of an irregular shape then place one pyramid yantra on each corner of the plot in addition place pyramid yantras in the Brahmasthala.



**(15) Complicated premises**

For some complicated premises and plots take help of a dowsing tool to find out low energy slots and then balance them with installation of pyramid yantra.

As a general rule if you place one pyramid yantra in every room it gives best effects, clears all minor Vastu ‘doshas; (if any), brings good luck and reflects bad energies.

## **Installation of Pyramid Yantra**

When installing your pyramid yantra always check whether it is perfectly oriented with one of its side facing any one of the directions -N, S, E, and W. If you install your pyramid yantra on the wall, stick it with the help of double adhesive foam tape and if you install in land, dig a pit of 1.5 feet, place the pyramid yantra there and then cover the soil.

\*\*\*\*\*

## **38. INTRODUCTION ABOUT FENG - SHUI**

---

---

The flow of energy dissipated by wind stops at the boundary of water. Hence the word of Feng Shui means Wind & water respectively. It is generally believed that the emerging refers to certain abstract natural forces which run with the line of landscape and also effect the people. This energy has become known as Feng Shui having marked influence on the environment and human life.

In fact, from our vedas & other ancient scriptures, many foreigners from East and Western countries have translated them, understood the inner meanings and have helped people in discovering the basic rules to add peace, prosperity & happiness in our lives. We have also propogated their Feng Shui all over the world whereas our Vaastu has hardly crossed our continent.

In Feng Shui there are good numbers of remedial measures for rectifying the Vaastu mistakes in existing buildings both within and outside the premises. Some of the remedial measures are us under :

- 1.) Mirrors cure**
- 2.) Bagua mirror**
- 3.) Crystals**

- 4.) **Lights**
- 5.) **Sounds**
- 6.) **Colours**
- 7.) **Heavy objects**
- 8.) **Plants**
- 9.) **Bamboo flutes**
- 10.) **Electrical Equipments**
- 11.) **Water fountains**
- 12.) **Energy Symbols**

\*\*\*\*\*

## **39. OVERCOMING VAASTU DEFECTS BY USING FENG - SHUI GADGETS**

---

---

We shall discuss how feng shui cures can be employed to stimulate the environment inside a structure.

We may mention here that feng shui cures can be employed in two ways. One way is to apply them from individual point of view. Here if a person is looking for improvement in business then the cures are employed in the business premises. If he is an Executive in a large organization looking for career advancement then the cures are employed in his office room. If he is looking for improvement in marital relationship then they are installed in the bed room and so on. In other words here the individual and what he desires most at that particular phase of his life are the guiding factors while placing the cures.

The same feng shui cures can also be employed for energizing various sectors of a house or apartment without bringing the individual in the picture. This procedure is ideal for homes and apartments where a family lives and the progress of all family members is desired.

The gadgets are found to be sufficient to fully stimulate the environment in individual houses or apartments. If your house or apartment is against vaastu then it is worth while trying the feng shui cures.



First have a plan of your house or apartment. Look at the general shape of the plan. If it is a rectangle or a square then you can proceed further to install the cures.

If a corner is missing then a correction is called for. To find the missing corner divide the plan to nine equal parts as shown below .

<b>North West</b>	<b>North</b>	<b>North East</b>
<b>West</b>	<b>Centre</b>	<b>East</b>
<b>South West</b>	<b>South</b>	<b>South East</b>

Placing the plan in this nine square matrix you can determine which area of your house or apartment comes under the influence of a particular sector.

Ideally no corner should be missing in a house or a apartment. But some times it is the case with houses and more so in case of an apartment. There is however no need to lose heart. All you have to do is to locate the missing corner. The defect can be overcome by using mirrors.

Let us take an example. In the following example you find that the northeast corner is missing. To re-establish the corner install two full length mirrors at the places shown. As you can see this gives an illusion of a northeast which is present.

<b>North West</b>	<b>North</b>	
<b>West</b>	<b>Centre</b>	<b>East</b>
<b>South West</b>	<b>South South</b>	<b>East</b>

Any missing corner defect can be rectified by this method. However make sure that the mirrors are installed properly. Firstly a mirror used for this purpose should be of high quality without any distortions. Secondly you need a mirror which is of shoulder width and atleast six feet in length. Two such mirrors are required.

The mirror should be permanently fixed on the walls. In the above case one mirror should be placed on the north wall and another on the east. The bottom line of the mirror should rest of the floor. Use always a single length. In other words you should not use more than one mirror to make up for the length.

In the rare case when you have more than one corner missing the same procedure is to be followed for the other missing corner also.

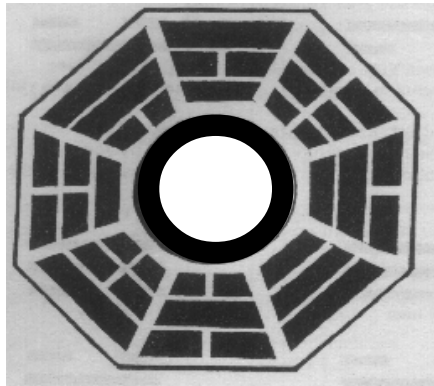
There is yet another possibility. You can have a building where a central direction sector is fully or partially missing.

<b>North West</b>	<b>North</b>	<b>North East</b>
<b>West</b>	<b>Centre</b>	<b>East</b>
<b>South West</b>	<b>South</b>	<b>East</b>

You find that the North sector is missing in the building. In this case install a mirror as above at the point shown. This in effect restores the cut portion. Once you have made sure that all sectors and corners are present, you can proceed to install the gadgets.

**PAKUA MIRROR**

A pakua mirror is used to ward off wrong vibrations entering a building mostly through the main door. The wrong or harmful Chi will be emanating from a distant point due to secret arrows. It may be an ugly looking tree in front of your house or the roof line of the opposite building or the cross of a church or a temple tower. It may not rows can get formed at great distances and the house can still be receiving bad Chi although you may not find any source of secret ar-



rows in front or at the back of your building. It is therefore always safe to install a pakua mirror on the front door. If you have a back door

to the house then it is advisable to have one more pakua mirror installed over it so that both doors are safe.

A pakua mirror consists of a round convex mirror mounted at the center of an Octagonal shaped pakua. In the pakua all sectors are represented with their respective colors and symbols. The octagonal plate is made out of high grade plastic stone or wood to with stand out door use.

A pakua mirror is to be installed outside only. It should never be used inside a building. Locate a place which is above the center point of the main door frame (or back door as the case may be) and roof line. Ideally it should be placed at equal distance from the roof line and door frame.

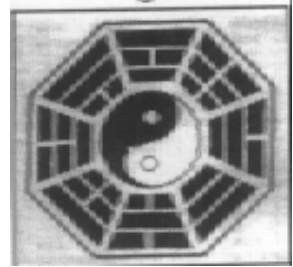
Hang the pakua mirror with the help of the back hook provided after inserting a nail to the wall. You can use double side tape also for extra protection.

A Bagua is similar in all respects to the pakua mirror the only difference being that in the center there is no mirror but the mirror is replaced with a YIN-YANG

## **BAGUA**

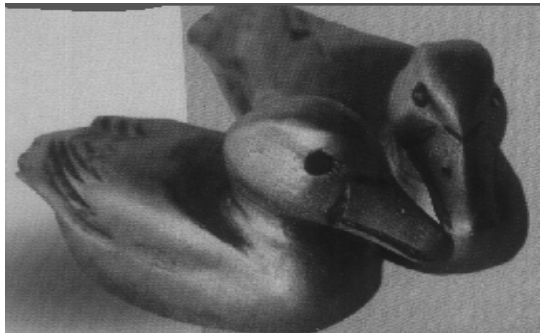
The door Bagua comes with a red thread for easy hanging. The Bagua is to be hung on the door frame of the master bed room. If you are using it in an office then it should be hung on the door frame of your office cabin.

A pakua/ Bagua is believed to prevent wrong vibrations entering the room and also prevents the good vibrations leaving the room.



## **MANDARIN DOVES**

The doves are made out of high quality wood and confirm to the stipulated guide lines of Feng Shui masters. The pair consists of male and female. They should always be kept together one by the side of the other not one facing the other.



The ideal place to keep the mandarin doves is the South West master bed room. The exact location is unimportant. What is more important is that it should be placed at such a place then you can look at it while lying on the bed. They should be easily

and wife and make life more harmonious.

They are also recommended to be placed in the room of a spinster or bachelor on the look out for a suitable life partner. It is believed by Feng Shui experts that marriage does take place in a short span if the doves are placed in the room of the needy.

## **CRYSTAL**

Natural quartz crystals are energy enhancers. The crystal which is cut at different angles to reflect light all round energizes an area.

Ideally it should be hung in the Northwest corner of the building or in the Northwest room. It helps to improve relationships between the family members. It also brings in helpful people to your life. It improves money matters and brings good luck.

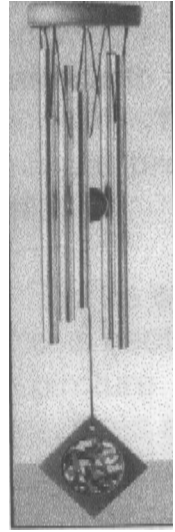
Keeping crystal pyramid enhances purity, concentration and absorb negativity.

For Vaastu defects crystal balls are extremely useful e.g. kitchen & bathroom in one line or opposite to each other, main door facing kitchen, or one door in front of other door etc.



## WIND CHIMS

Wind Chims are very useful Feng-Shui gadgets. Install silver /white colour Five Rods metallic wind chimes in west of your house/ room/ office to get family happiness and mental rest, a golden /yellow colour metallic wind chime in Northwest of your house / office/ room will entrance foreign travel/ new opportunity, & helpful people.



\*\*\*\*\*

## **40. 21 FENG-SHUI TIPS FOR EXCELLENT RESULTS**

---

---

your space. Make that first eye contact a powerful & beautiful impression for yourself.

**2.)** In your office, you should always sit with a solid wall behind your back and as far from the gate as possible to have support from bosses, colleagues & friends. If you do not wish your manager to over power you then do not give him a solid wall behind his seat.

**3.)** Looking for better foreign contacts ?

Put Globe on North West corner to get better overseas opportunities and rotate it atleast three times in a day in clockwise direction.

**4.)** If you wish to buy a new flat or house without consulting any Fengshui consultant, bring a 'new born baby' there. If she cry's, it means the house does not have good feng shui. If she smile that means that house has good Feng shui.

**5.)** Have name plate & number of your house on door. So that opportunities can trace you easily.

**6.)** Are you looking for a potential client ?

Place your address book or planner on North West corner of the desk.

**7.)** Do not complain all the time as this will create



sha chi (Negative Energy).

**8.)** Do you want to improve the energy level of house ?

Ring the Tibetan bell for powerful energy in your house.

**9.)** Want to improve the study of your children ?

Put Crystal on North East corner of the study table for excellent study of your children.

**10.)** Do you want to retain the money in the house ?

Put a 3 leg frog facing main door for better saving. Take care that the back of the Frog face your main door.

**11.)** Never accept money between two fingers, as this is seen as cutting image.

Accept the money with five fingers.

**12.)** Do not sleep on a double bed with two different mattress. This creates a symbolic separation that could become real.

**13.)** Never sit with your back facing main door. Unwanted guest should be given such seat.

**14.)** Want to improve marriage prospects ?

Hang crystal & light in South West corner. Keep Rose Quartz in South West of your room.

**15.)** Want to remain healthy ?

Remove medicine from kitchen & shift to living room.

**16.)** Never keep unrepai

telephone, mixer, spoiled ball pens, cassettes etc. in the house. This will create negative energy in the house.

**17.)** Check the door bell sound of your house. If it sounds irritating, family members will be short tempered. If it sounds dull voice, energy level of the house will be low. The door bell sound should be pleasing.

**18.)** Want to improve the Sales ?  
Stick three Chinese coins tied with red ribbon on sales file or invoice book or order book.

**19.)** Check if any marble or tile is broken in your house or office. This could result into broken relationship with family member or partner or customers. Put carpet to cover the broken marble/tiles or replace it.

**20.)** Is there any tree facing your main door or window ?

This could result into poor health of family members. Place convex mirror on the outer wall facing that tree.

**21.)** Is your wife facing cervical problems, pain in leg and backache.

This is due to her back facing at the entrance gate of the kitchen install a convex mirror in front of her so that she can see what is going on in her backside through the mirror.

\*\*\*\*\*